

SST SERIES PART POSITIONER

**ONE ACTUATOR TO EXTEND AND TIP TOOLING AWAY
REPEATABLE RETRACTED POSITION**

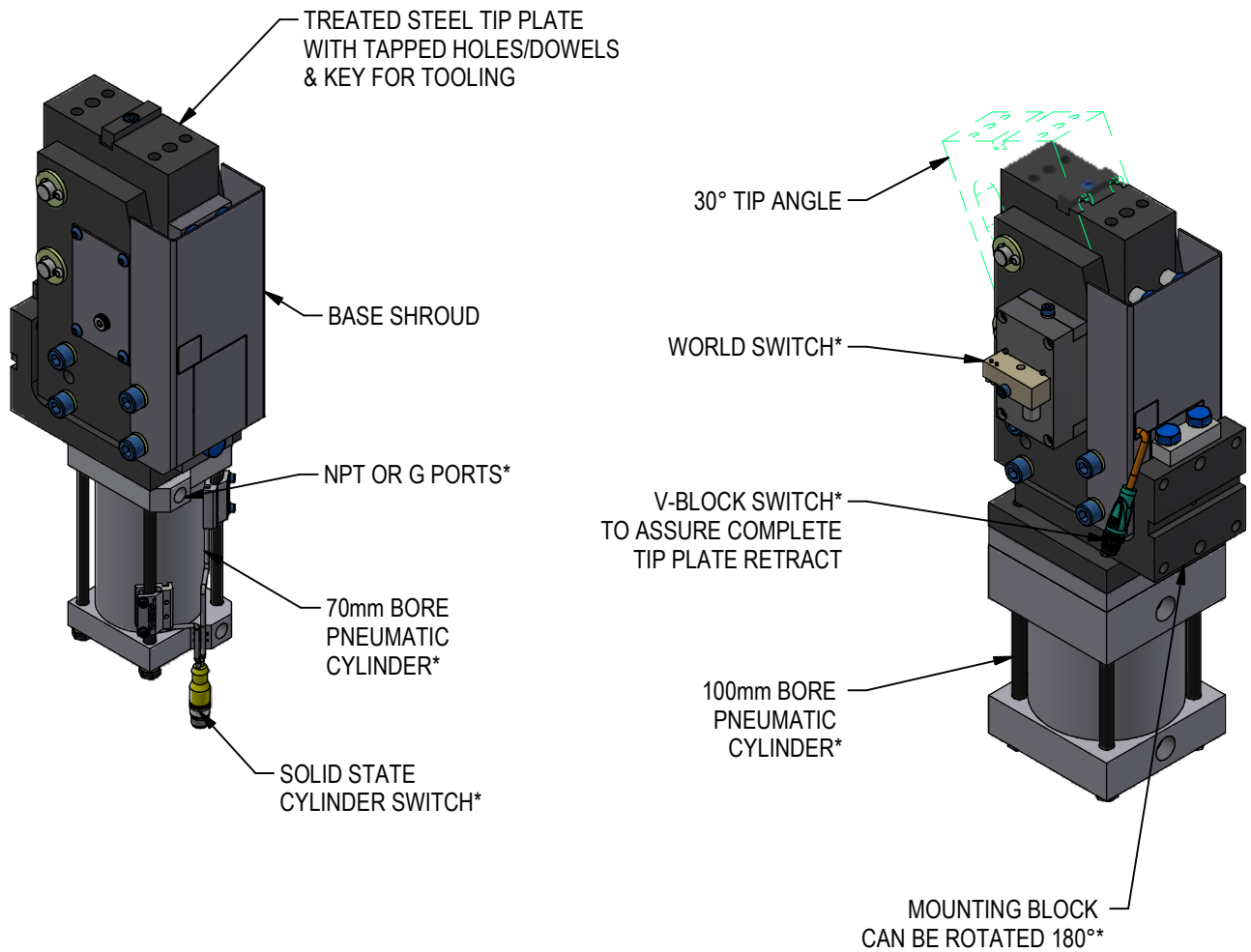

*OPTIONAL

PART POSITIONER CONFORMS
TO INDUSTRY STANDARD
REPEATABILITY TOLERANCES
FOR GEOMETRY STATIONS

MINIMUM 2-SECOND CYCLE TIME FOR ONE DIRECTION

RELEASED 10/28/22

ORDERING INFORMATION

NOTE: ALL BOXES MUST BE FILLED IN FOR A COMPLETE PART NUMBER

S	S	T	0	3	0	A									0	0
---	---	---	---	---	---	---	--	--	--	--	--	--	--	--	---	---

Actuator (See Sheet 5)

- 01 Welker 70mm Bore with NPT Ports
- 02 Welker 70mm Bore with G Ports
- 05 Welker 100mm Bore with NPT Ports
- 06 Welker 100mm Bore with G Ports

Shroud (See Sheet 6)

- 0 Base Shroud
- 1 Extra Tip Plate Shrouding*

Mount (See Sheet 7)

- A Mounting Base as Shown
- B Mounting Base Rotated 180 degrees

Switch Options (See Sheets 8, 9)

Switch Position (See Sheets 8, 9)

- 1 Switch @ Position 1
- 2 Switch @ Position 2
- 3 Switch @ Position 3
- 4 Switch @ Position 4

Port Position (See Sheet 5)

- A Port @ Position 1
- B Port @ Position 2
- C Port @ Position 3
- D Port @ Position 4

V-Block Switch (See Sheet 10)

- 0 No V-Block Switch
- S V-Block Switch

*Extra tip plate shrouding not available on SST with World Switch



UNIT WEIGHTS**	
UNIT	WEIGHT (LBS)**
70mm BORE CYLINDER	44.5
100MM BORE CYLINDER	54.5

**WEIGHTS SHOWN ARE APPROXIMATE AND WILL VARY WITH OPTION SELECTION.

MINIMUM 2-SECOND CYCLE TIME FOR ONE DIRECTION

(DO NOT SCALE DRAWING)

ENGINEERED PRODUCTS

(800) 229-0890 www.welkerproducts.com

DIMENSIONS

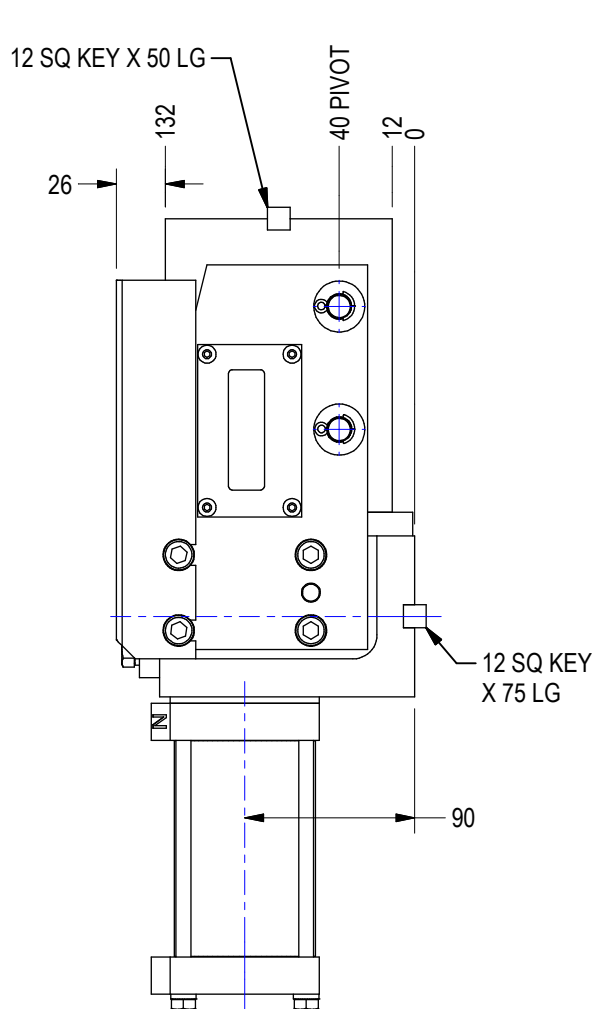
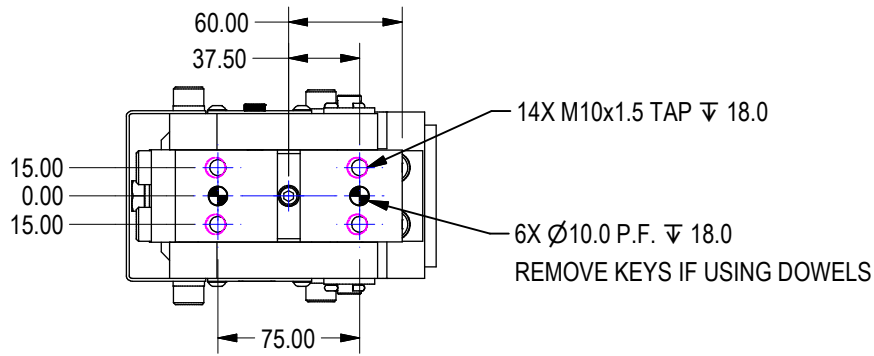

UNIT SHOWN RETRACTED

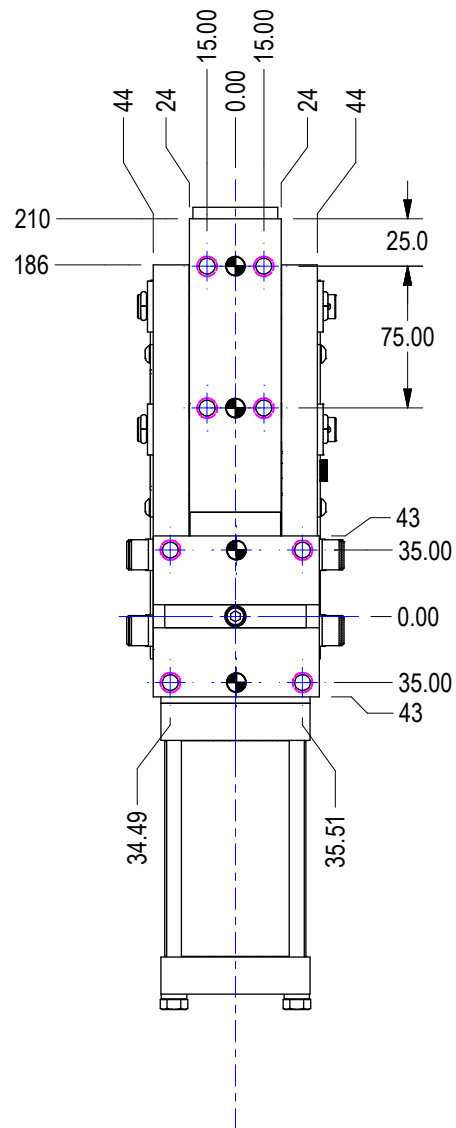

MINIMUM 2-SECOND CYCLE TIME FOR ONE DIRECTION



WELKER PART POSITIONER
WEB PAGE

(DO NOT SCALE DRAWING)

WELKER
ENGINEERED PRODUCTS
(800) 229-0890 www.welkerproducts.com

TIP ANGLE INFORMATION

S S T 0 3 0 A 0 1 0 A L 3 1 A 0 0 0

Angle
SST 30

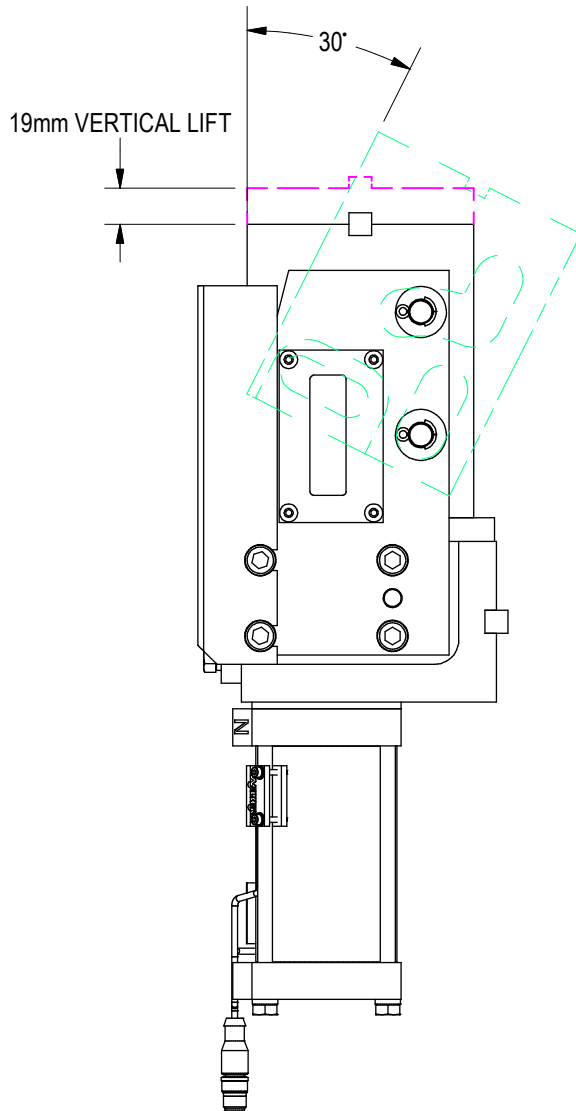

UNIT'S TIP PLATE TRAVELS
VERTICALLY THEN TIPS OUT TO 30°

TIP PLATE CONTINUES TO
TRAVERSE UNTIL CYLINDER
STROKE IS COMPLETE.

MINIMUM 2-SECOND CYCLE TIME FOR ONE DIRECTION

SHEET 4

(DO NOT SCALE DRAWING)

WELKER

ENGINEERED PRODUCTS

(800) 229-0890 www.welkerproducts.com

ACTUATOR INFORMATION

S
S
T
0
3
0
A
0
1
0
A
L
3
1
A
0
0
0

Actuator

- 01 Welker 70mm Bore w/ NPT Ports
- 02 Welker 70mm Bore w/ G Ports
- 05 Welker 100mm Bore w/ NPT Ports
- 06 Welker 100mm Bore w/ G Ports

Port Position

- A Port @ P1
- B Port @ P2
- C Port @ P3
- D Port @ P4

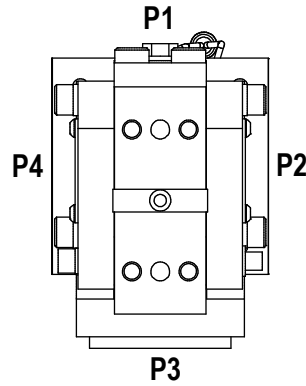

PORTS SHOWN AT
"C" POSITION P3

**ACTUATOR OPTIONS
01 - 02**

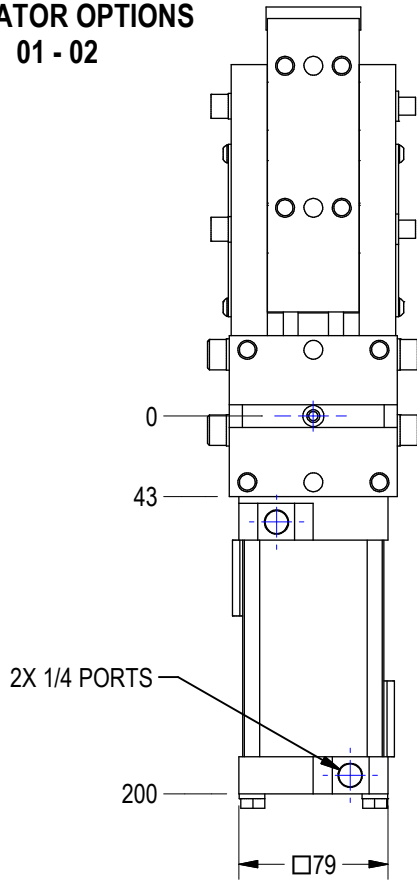

**ACTUATOR OPTIONS
05 - 06**

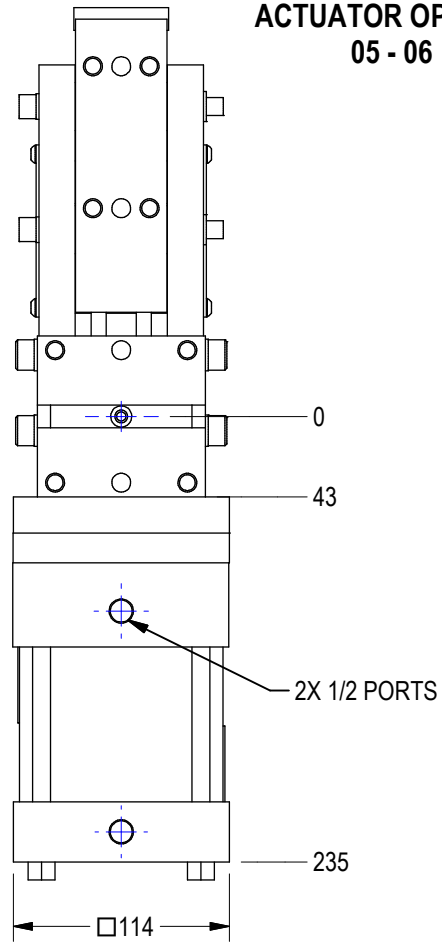

TIP ANGLE	CYLINDER STROKE
30°	50

NOTE: DIMENSIONS SHOWN ARE mm

MINIMUM 2-SECOND CYCLE
TIME FOR ONE DIRECTION

(DO NOT SCALE DRAWING)

ENGINEERED PRODUCTS

(800) 229-0890 www.welkerproducts.com

SHROUD INFORMATION

S
S
T
0
3
0
A
0
1
0
A
L
3
1
A
0
0
0

Shroud

- 0 Base Shroud
- 1 Tip Plate Shrouds
(Recommended for heavily contaminated environments such as MIG and arc welding)

NOTE: SHROUD OPTION "1" IS NOT AVAILABLE ON SST WITH WORLD SWITCH

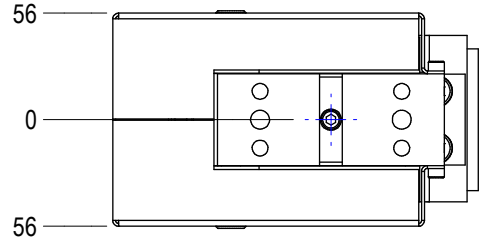

**TIP PLATE SHROUDS
OPTION "1"**

**BASE SHROUD
OPTION "0"**

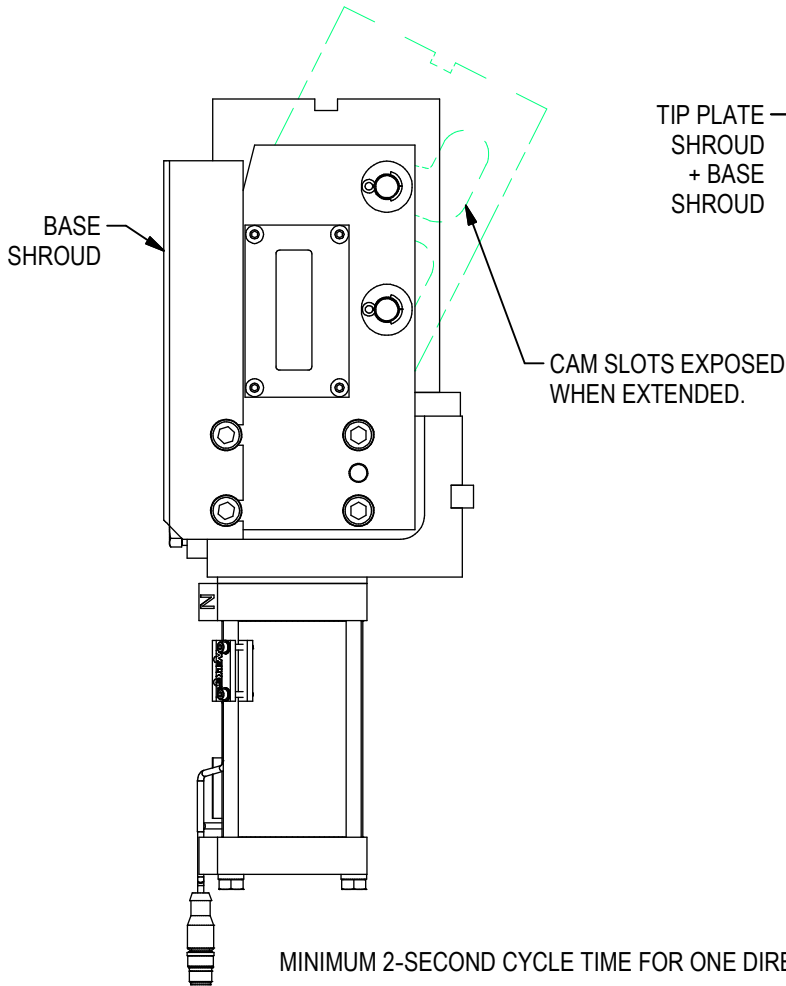

TIP PLATE SHROUD + BASE SHROUD

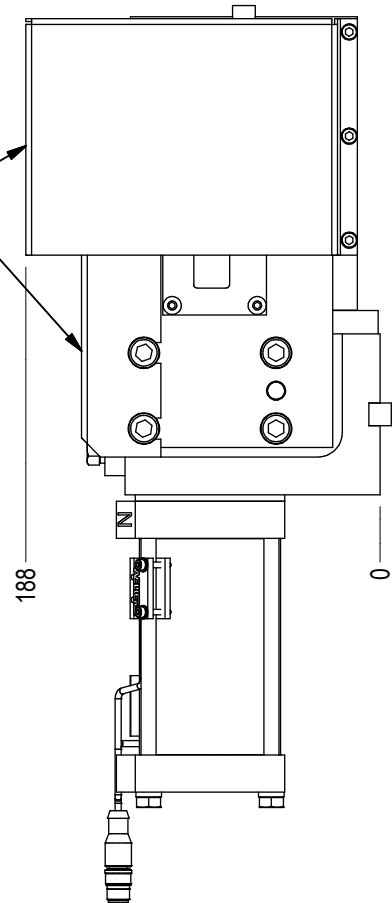

(DO NOT SCALE DRAWING)



ENGINEERED PRODUCTS

(800) 229-0890 www.welkerproducts.com

MINIMUM 2-SECOND CYCLE TIME FOR ONE DIRECTION

MOUNT INFORMATION

S S T 0 3 0 A 0 1 0 **A** L 3 1 A 0 0 0

Mount _____

- A Base Mount @ 0
- B Base Mount @ 180

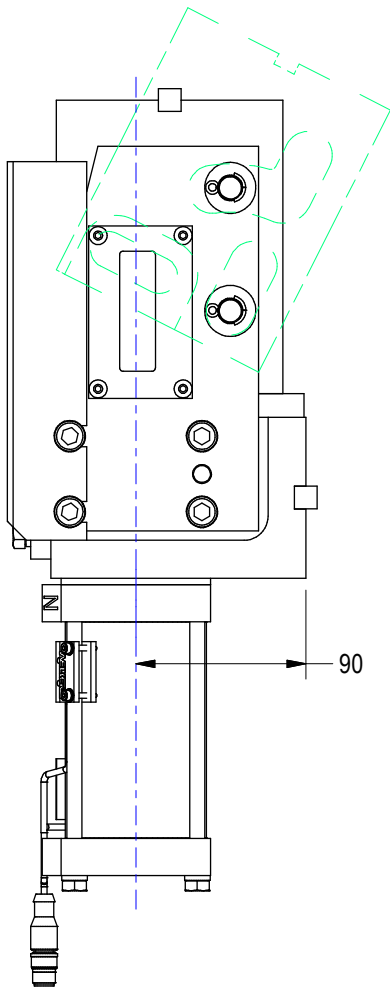

MOUNT "A"

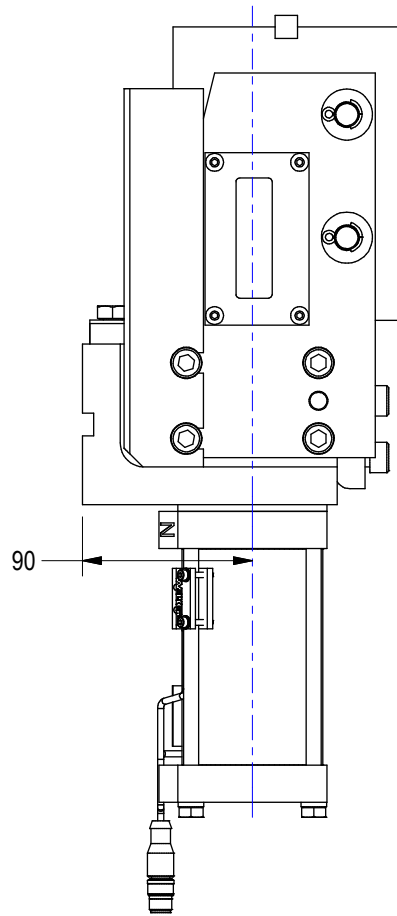

MOUNT "B"

MINIMUM 2-SECOND CYCLE TIME FOR ONE DIRECTION

(DO NOT SCALE DRAWING)



ENGINEERED PRODUCTS

(800) 229-0890 www.welkerproducts.com

WORLD SWITCH INFORMATION

S
S
T
0
3
0
A
0
1
0
A
L
3
2
A
0
0
0

Switch Options

- L3** Solid State Cylinder Switch (See sheet 9)
- AE** World Switch (see chart below)

Switch Position

- 2** Switch @ Position 2
- 4** Switch @ Position 4

WORLD SWITCH CHART

	Order Number SO1 EXTEND / SO1 RETRACT	Part Number	Manufacturer	Description All switches Quick Disconnect
	ZE / ZR	WWS001A	Welker	4-Wire, 4-Pin, DC M12 X 1 (PNP)
	Standard Switch Option - All other options may affect price and delivery			
	Non-stocked switches (effective 1-2-2023):			
SST World Switches	AE / AR	Ni2-Q6.5-AP6-0.1-FS 4.4X3/S304	Turck	4-Wire, 4-Pin, DC M12 X 1 (PNP)
	BE / BR	Ni2-Q6.5-ADZ32-0.1-FSB 5.4X4/S304	Turck	4-Wire, 5-Pin, AC/DC 1/2-20 (N.O.)
	CE / CR	Ni2-Q6.5-AN6-0.1-FS 4.4X3/S304	Turck	4-Wire, 4-Pin, DC M12 X 1 (NPN)
	DE / DR	NBN2-F581-100S6-E8-V1	Pepperl & Fuchs	4-Wire, 4-Pin, DC M12 X 1 (PNP)
	EE / ER	BES-Z02KR2-PSC20F-P100-S04-V	Balluff	3-Wire, 4-Pin, DC M12 X 1 (PNP)
	HE / HR	Ni2-Q6.5-0.1-BDS-2AP6X3-H1141/S34	Turck	4-Wire, 4-Pin, DC M12 X 1 (PNP)
	JE / JR	IN5374	Efector	3-Wire, 4-Pin, DC M12 X 1 (PNP)

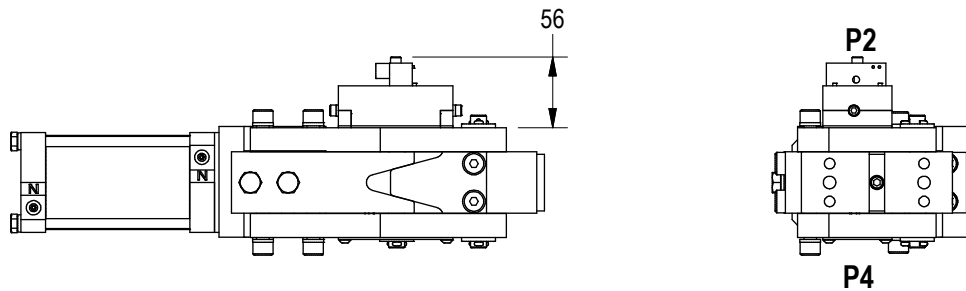

VIEW SHOWN WITH WORLD SWITCH
 WORLD SWITCHES ARE AVAILABLE **ONLY** WITH SWITCH POSITIONS 2 & 4.
 TIP PLATE SHROUD ONLY - NOT AVAILABLE WITH WORLD SWITCH ON SST

MINIMUM 2-SECOND CYCLE TIME FOR ONE DIRECTION

(DO NOT SCALE DRAWING)

ENGINEERED PRODUCTS

(800) 229-0890 www.welkerproducts.com

CYLINDER SWITCH INFORMATION

S
S
T
0
3
0
A
0
1
0
A
L
3
1
A
0
0
0

Switch Options

- L3** Solid State Cylinder Switch (see chart below)
- AE** World Switch (see sheet 8)

Switch Position

- 1** Switch @ Position 1
- 2** Switch @ Position 2
- 3** Switch @ Position 3
- 4** Switch @ Position 4

	Switch	Part Number	Manufacturer	Description
Cylinder Switches	L3	SWITCH L3* L3 switch is weld field immune, comparable to World Switches. Dual sensor switch, 1 per cylinder	Welker	4-Wire, 4-Pin, DC (PNP) M12 X 1 Quick Disconnect
	L5	MK5113 Single sensor switch, 2 switches per cylinder	ifm Efector	3-Wire, 4-Pin, DC (NPN) M12 X 1 Quick Disconnect

Standard Switch Option - All other options may affect price and delivery

*Note that some mid and low frequency DC resistance applications (i.e. aluminum resistance welding applications) may cause a fault. In these applications, it is recommended that the sensor be ignored/bypassed during the welding cycle.

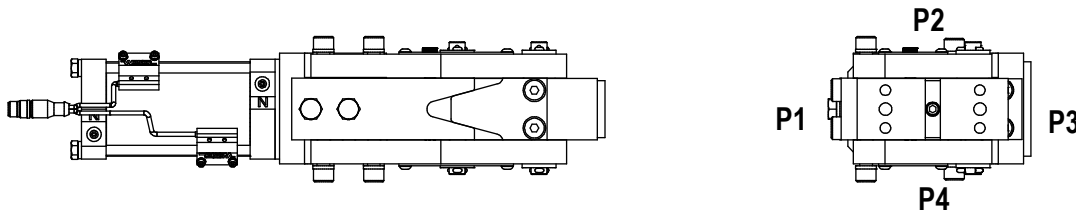

VIEW SHOWN WITH SOLID STATE CYLINDER SWITCH IN POSITION 1

MINIMUM 2-SECOND CYCLE TIME FOR ONE DIRECTION

(DO NOT SCALE DRAWING)

WELKER

ENGINEERED PRODUCTS

(800) 229-0890 www.welkerproducts.com

V-BLOCK SWITCH INFORMATION

S
S
T
0
3
0
A
0
1
0
A
L
3
1
A
0
0
0

Mount

- A Base Mount @ 0
- B Base Mount @ 180

V-Block Switch Options

- 0 No V-Block Switch
- S V-Block Switch

NOTE: BASE SHROUD NOT SHOWN FOR CLARITY

V-BLOCK SWITCH MOUNT "A"

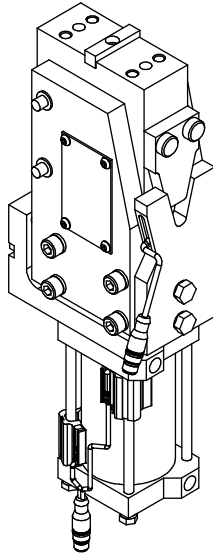

V-BLOCK SWITCH MOUNT "B"

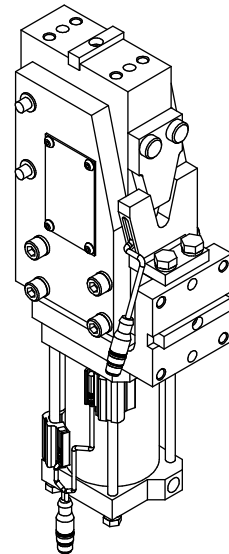

V-BLOCK SWITCH FEATURES:

LEDS: GREEN = POWER ON, YELLOW = OUTPUT

EUROFAST M12X1 MALE 4 PIN CONNECTOR
 CABLE TYPE: WELD SPATTER RESISTANT, ROBOT QUALITY, POC
 CABLE LENGTH: 255mm

FOR DETAILED SWITCH SPECIFICATIONS
 SEE WELKER SMART STOP CATALOG

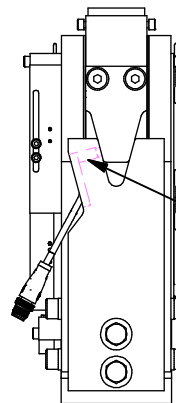

SWITCH IS EMBEDDED IN LOWER WEDGE PLATE TO ENSURE COMPLETE TIP PLATE RETRACT

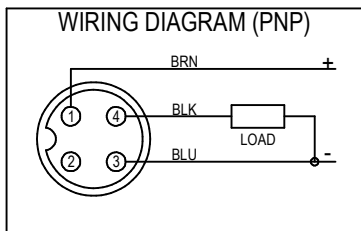

MINIMUM 2-SECOND CYCLE TIME FOR ONE DIRECTION

SHEET 10

(DO NOT SCALE DRAWING)

ENGINEERED PRODUCTS

(800) 229-0890 www.welkerproducts.com

SST PART POSITIONER APPLICATION DATA: 70mm BORE CYLINDER

VERTICAL APPLICATIONS

NOTE: CENTER OF GRAVITY AND PART CONTACT TOOLING MUST BE WITHIN DESIGNATED ZONE

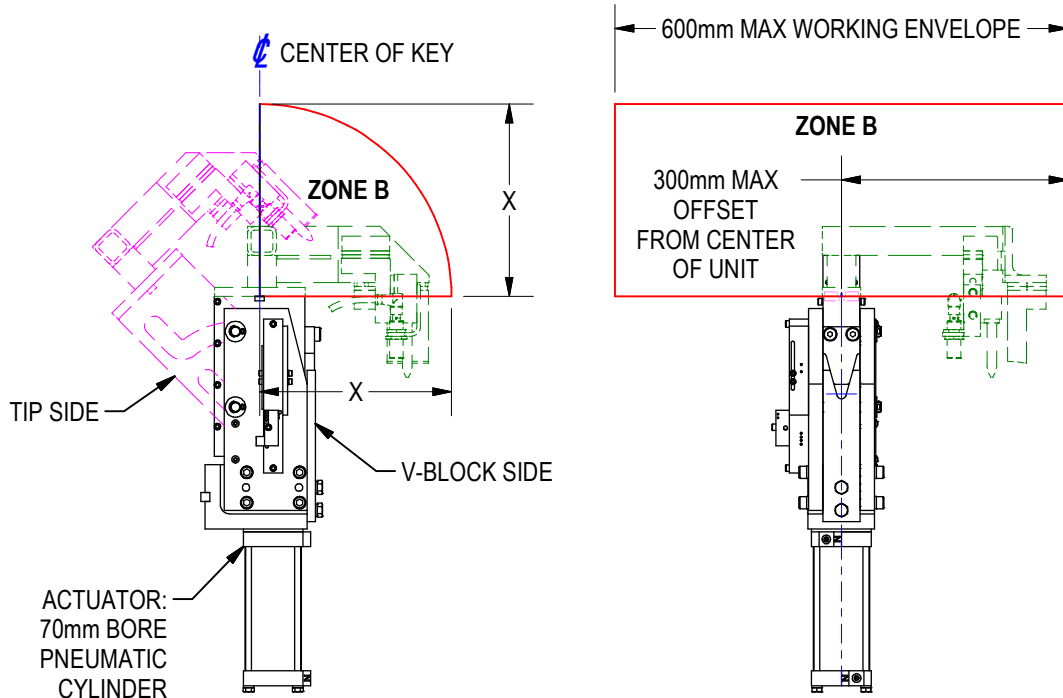

70mm BORE CYLINDER		
ZONE	DIM X	MAX LOAD
B	152mm (6")	70 LBS @ 60 PSI
	152mm (6")	70 LBS @ 80 PSI
	254mm (10") MAX	30 LBS @ 60 PSI
	254mm (10") MAX	40 LBS @ 80 PSI
C	254mm (10")	10 LBS @ 60 PSI
	254mm (10")	18 LBS @ 80 PSI

HORIZONTAL APPLICATIONS

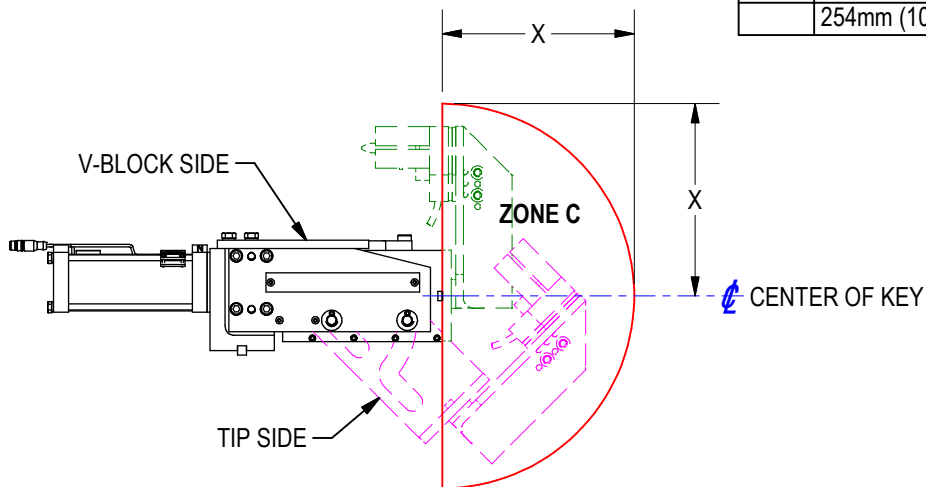

MINIMUM 2-SECOND CYCLE TIME FOR ONE DIRECTION

(DO NOT SCALE DRAWING)

WELKER

ENGINEERED PRODUCTS

(800) 229-0890 www.welkerproducts.com

SST PART POSITIONER APPLICATION DATA: 100mm BORE CYLINDER

VERTICAL APPLICATIONS

NOTE: CENTER OF GRAVITY AND PART CONTACT TOOLING MUST BE WITHIN DESIGNATED ZONE

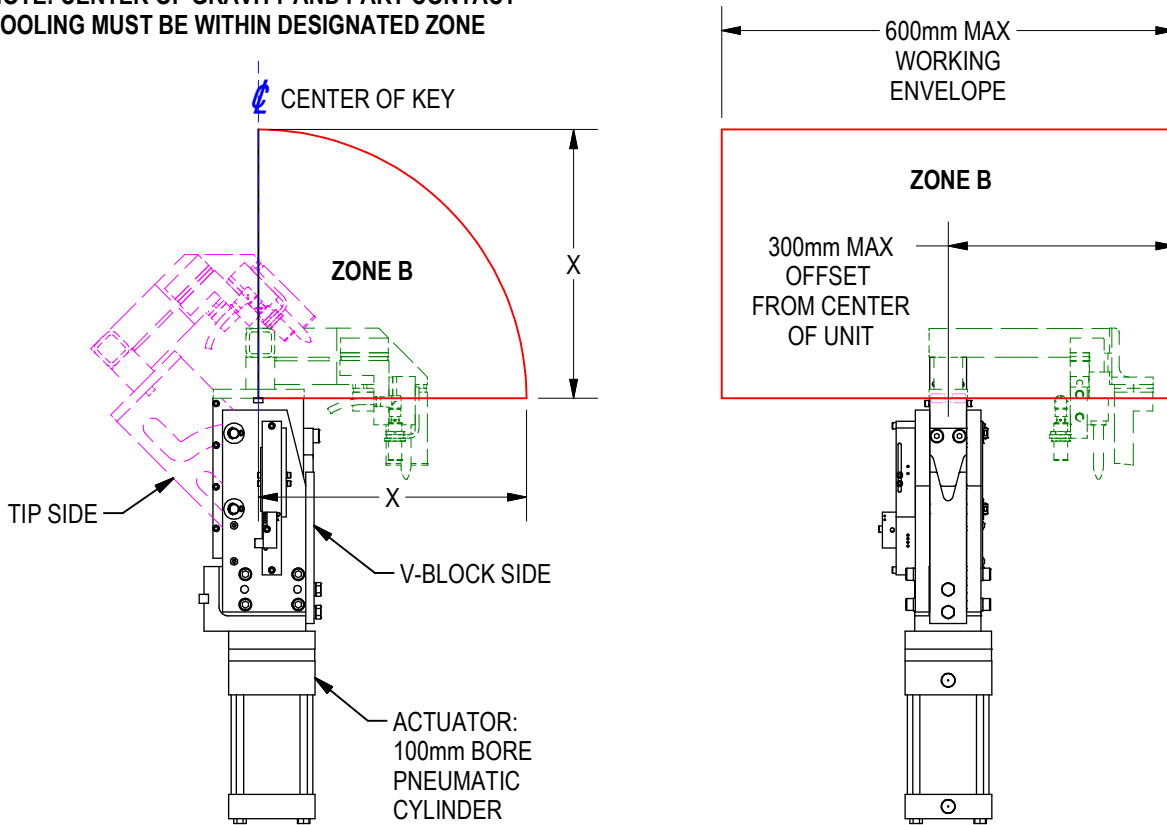

HORIZONTAL APPLICATIONS

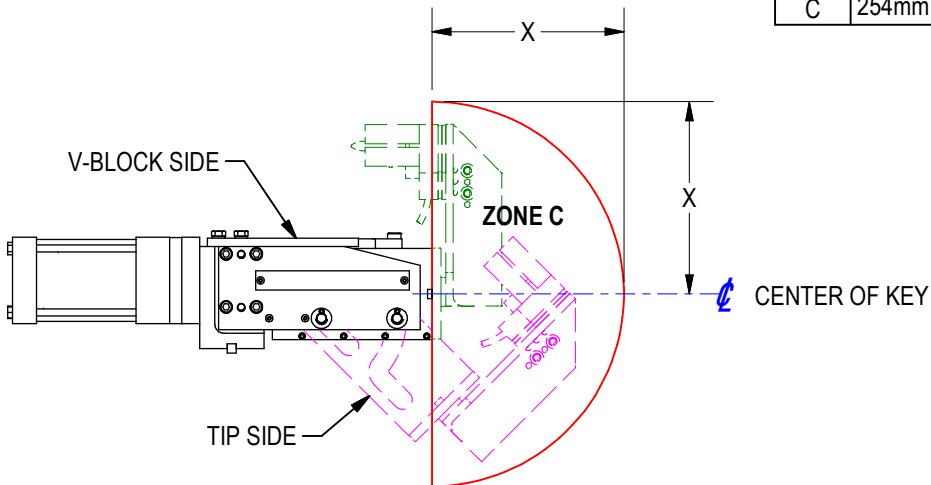

100mm BORE CYLINDER		
ZONE	DIM X	MAX LOAD
B	355mm (14") MAX	45 LBS @ 60 PSI
	355mm (14") MAX	60 LBS @ 80 PSI
C	254mm (10")	30 LBS

MINIMUM 2-SECOND CYCLE TIME FOR ONE DIRECTION

(DO NOT SCALE DRAWING)



ENGINEERED PRODUCTS

(800) 229-0890 www.welkerproducts.com

SST PART POSITIONER: REQUIRED CRITERIA FOR APPLICATION APPROVAL

APPLICATION DATA MUST BE SUBMITTED FOR WELKER APPROVAL WITH THE FOLLOWING CRITERIA FOR ALL PART POSITIONER APPLICATIONS. PLEASE ATTACH THIS WORKSHEET TO YOUR BUY OFF AND INCLUDE A MINIMUM OF TWO SCREEN SHOTS OF YOUR APPLICATION WITH UNIT TIP PLATE IN EXTENDED POSITION.

FLOW CONTROLS ARE REQUIRED FOR ALL APPLICATIONS.

REF	DESCRIPTION	VALUE
	WELKER UNIT PART NUMBER	
	WEIGHT/MASS OF LOAD (TOOLING PLUS PARTS)	lbf
C	DISTANCE FROM PIVOT POINT TO LOAD CENTER OF GRAVITY	mm
D	DISTANCE FROM PIVOT POINT TO LOAD CENTER OF GRAVITY	mm
E	DISTANCE FROM CENTER OF KEYWAY TO LOAD CENTER OF GRAVITY	mm
F	ORIENTATION OF UNIT TO FLOOR	°

PLEASE SUBMIT VIEWS BELOW FOR APPROVAL

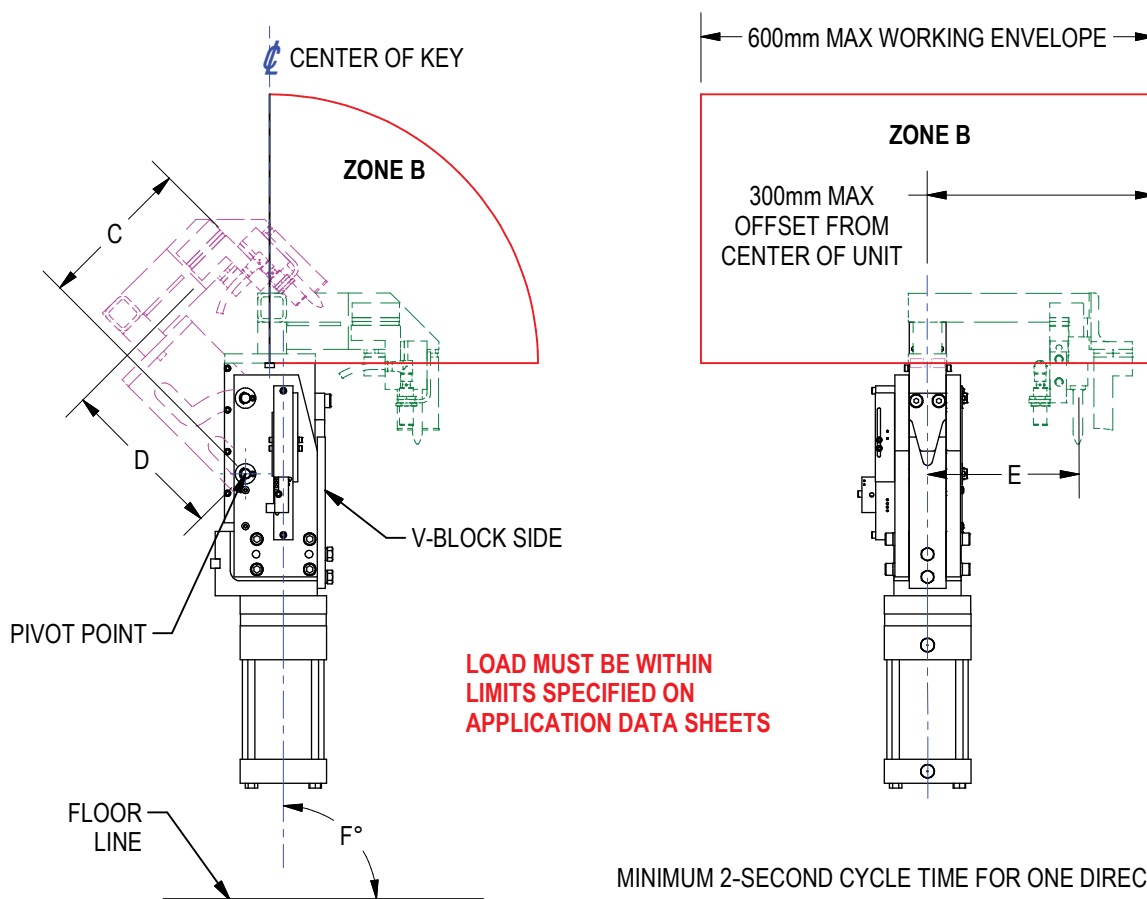

WELKER APPROVAL			
SUBMITTED BY		DATE	
PHONE NUMBER		EMAIL	
COMPANY NAME		PROGRAM	
WELKER APPROVAL BY		DATE	

ACTUATOR	EXTEND TORQUE	RETRACT TORQUE
70mm BORE CYLINDER	300in-lbf	225in-lbf
100mm BORE CYLINDER	600in-lbf	450in-lbf

(DO NOT SCALE DRAWING)

ENGINEERED PRODUCTS

(800) 229-0890 www.welkerproducts.com