

MAINTENANCE MANUAL R2 RAIL SLIDE

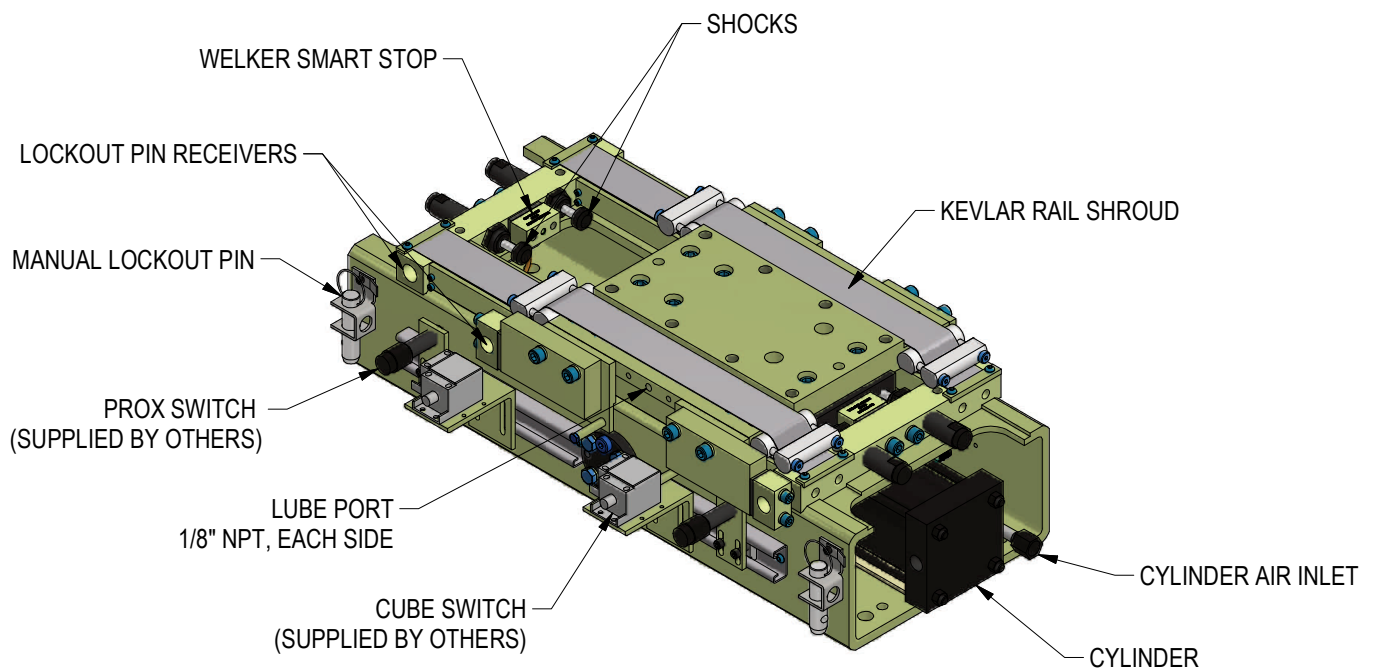

UNIT WITH AUTO-LUBE OPTION:

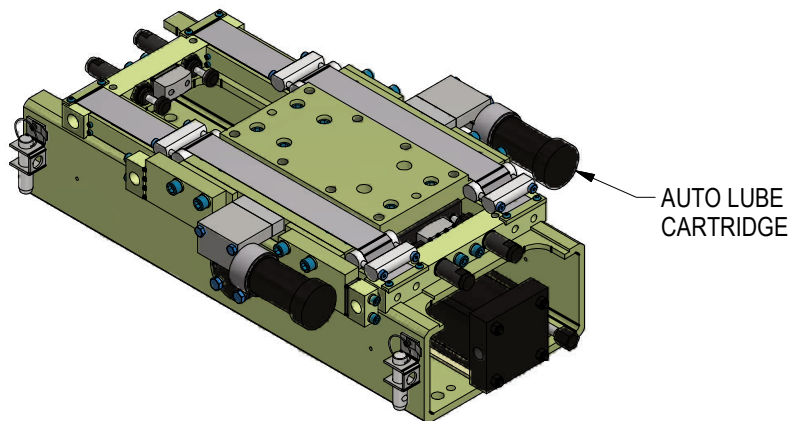

MAINTENANCE

SAFETY FIRST!

MAINTENANCE SHOULD ONLY BE PERFORMED BY QUALIFIED PERSONNEL. PROPER SAFETY GEAR AND PROCEDURES MUST BE USED AT ALL TIMES.

BEFORE PERFORMING MAINTENANCE, CUT OFF AIR SUPPLY TO THE UNIT, ENSURE THAT ALL AIR IS REMOVED AND THAT THERE ARE NO "TRAPPED AIR" CONDITIONS. SECURE SLIDE WITH LOCKOUT PIN TO PREVENT MOTION.

PREVENTATIVE MAINTENANCE: Regularly inspect unit to verify proper operation. Check for debris build up, especially between ends of rails and end blocks as too much contamination can jam debris into bearing block, past seals. Clean as needed. Inspect all pneumatic, electrical, and mounting connections, making sure all connections are tight and secure. Routine replacement of cylinder seals is recommended. Lubrication of bearings is required monthly if no auto lube option is present. Replace auto lube cartridges yearly.

CYLINDER: Welker pneumatic cylinders are lube free and require very little maintenance. Check rod and cylinder surfaces for abnormal wear or damage. Plant air supply to the cylinder should be free of contaminants; filtered to a minimum of 50micron; and have a water separator. Be sure fittings are in good condition. Seals are subject to wear under normal operating conditions. It is recommended to keep a spare cylinder seal kit or repair kit on hand.

STOPS: Shims (if applicable) may require adjustments; be sure to make adjustments to each location equally. Welker Smart Stop requires replacement upon failure. Welker Smart Stops use standard NAAMS (3) hole shims and spacers.

SHOCKS: Shocks are subject to wear under normal operating conditions and should be replaced when worn or cracked.

SHROUDS: Replace when damaged or torn.

BEARING ASSEMBLY & RAIL: Bearings must be relubricated every six months. Automatic bearing lubrication option is recommended. Inspect rails for damage and debris.

TROUBLESHOOTING

FAILURE	POSSIBLE CAUSE	SOLUTION
Slide carriage does not move or does not fully extend/retract	Cylinder/actuator failure	Check plant air supply for proper pressure; too little will result in lack of cylinder movement. Seals may be worn, damaged or deteriorating. Replace as needed. If cylinder has been serviced, be sure tie rod nuts have been tightened to torque specifications.
	Debris/contamination in slide	Inspect unit for dirt/debris. Clean, remove debris. Inspect shroud, replace if damaged.
	Stray metal parts in slide	Remove.
	Lockout pin engaged	Check lockout pin
Bent, broken, or worn cylinder rod	Misaligned load or load in excess of capacity	Make sure load is properly aligned and within design limits. Please call Welker for cylinder service or replacement.
Rail damage	Bearing failure Contaminants inside bearing assembly	Replace bearing assembly (includes 1 rail and 2 carriages)
Rail noise	Lack of bearing lubrication	Lubricate bearings.
Welker Smart Stop LEDs do not light up	Cylinder/actuator stroke not completing	Inspect unit for debris blocking full cylinder stroke. Clean, remove debris. Check cylinder operation.
	Switch failure	Check switch for proper operation and secure connection. Replace if required.

REPLACEMENT PARTS

NOTE A: When ordering cylinder repair/seal kits, please have the unit's Welker Job Number available and/or the cylinder model & serial number.

REPLACEMENT PARTS				
ITEM	QTY	STOCK*	DESCRIPTION	R2 PART NUMBER
1	1		PNEUMATIC CYLINDER WITH COUPLER	SEE CHART NEXT PAGE
2	2		BEARING ASSEMBLY: BEARING CARRIAGE (2) & RAIL (1)	SEE NOTE A
3	4	1	SHOCK ABSORBER	SC650M-9
4	2		MANUAL LOCKOUT PIN	FPC12-20R
5	2		MANUAL LOCKOUT PIN CABLE	FPC-8
6	2		SHROUD, KEVLAR	PRS25E19-OAL (500mm + STROKE)
7	2	1	SMART STOP	ASC021-PD
8	2		AUTOMATIC LUBE	PERMA PFLEX125-1175 OR NOVA-XHP222
	1	1	CYLINDER REPAIR KIT	(SEE NOTE A)

* RECOMMENDED SPARE PARTS TO KEEP IN STOCK

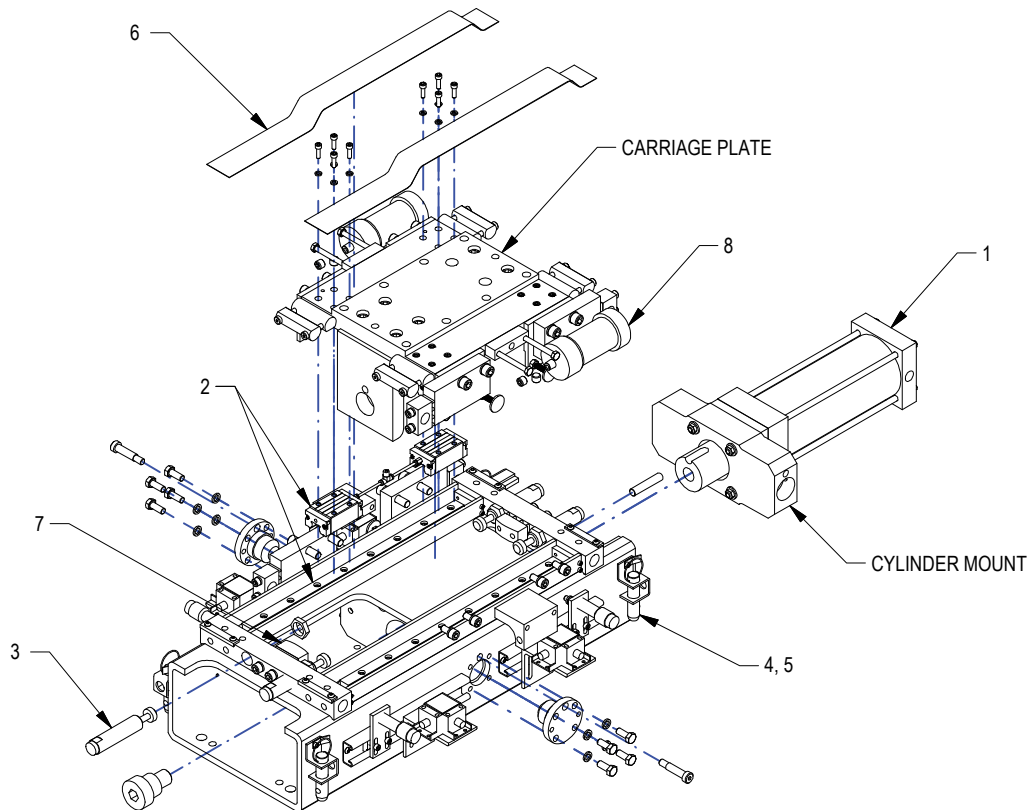

CYLINDER MAINTENANCE

TO REMOVE CYLINDER/COUPLER ASSEMBLY

1. Release air pressure from system and remove air lines from cylinder. Secure slide with lockout pin to prevent motion.
2. Remove cylinder coupler from coupler adapter at drive block.
3. Remove shoulder screws from both cylinder trunion pins. Remove fasteners, lock washers and trunion pins.
4. Slide cylinder/mounting block assembly horizontally out and away from unit. Note that cylinder coupler dowel will be loose.
5. Remove nuts & lock washers at mounting block to release cylinder. Coupler adapter is affixed to cylinder rod with permanent Loctite. To remove, first extend the cylinder rod to move the coupler adapter away from cylinder body. Then apply heat to the coupler to soften the thread locker. Use caution so as not to overheat the cylinder rod seals!

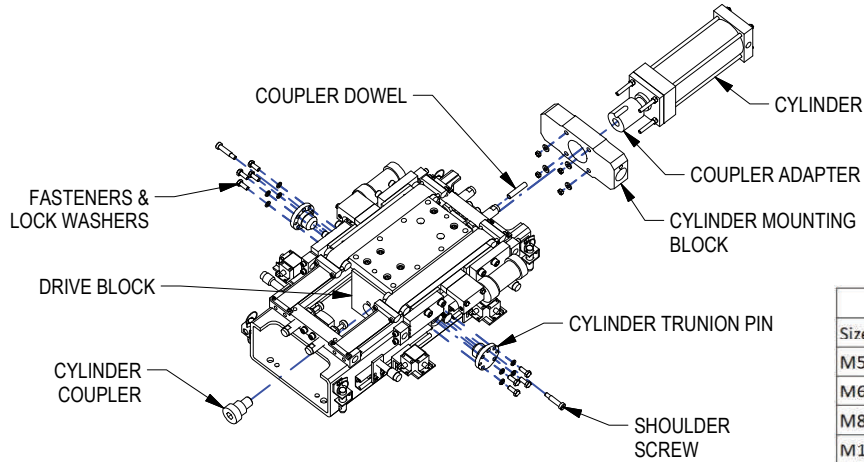

Tightening Torques for Metric Bolts (dry)				
Size	Steel		Aluminum	
	M5	10.0 Nm	7.4 ft lb.	5.0 Nm
M6	19.0 Nm	14.0 ft lb.	9.5 Nm	7.0 ft lb.
M8	45.0 Nm	33.2 ft lb.	22.5 Nm	16.6 ft lb.
M10	89.0 Nm	65.6 ft lb.	44.5 Nm	32.8 ft lb.
M12	156.0 Nm	115.1 ft lb.	78.0 Nm	57.5 ft lb.

TO REINSTALL CYLINDER/COUPLER ASSEMBLY

1. Make sure debris is cleared from the slide interior.
2. Install coupler adapter on cylinder rod using permanent Loctite (red). Bolt cylinder to mounting block, making sure cylinder aligns with air lines..
3. Reinstall coupler dowel in drive block. Align coupler adapter to dowel. Slide cylinder assembly on guides until mounting block touches head of guide screws.
4. Install trunion pins on both sides of slide, secure with shoulder screws. Install fasteners & lock washers.
5. Install cylinder coupler in coupler adapter, thru drive place, using removable Loctite (blue).
6. Tighten all fasteners to torque shown. Reinstall air lines.

REPLACEMENT CYLINDERS

CYLINDER	PORTS	CYLINDER TYPE	BRAKE	CYLINDER MODEL
01	NPT	Standard	Non-Locking	WC-2018-(Stroke + 25*)-R2 (*Minimum 225)
02	SAE	Standard	Non-Locking	WC-2019-(Stroke + 25*)-R2 (*Minimum 225)
03	G	Standard	Non-Locking	WC-2036-(Stroke + 25*)-R2 (*Minimum 225)
04	NPT	Standard	Locking	WC-2020-(Stroke + 25*)-R2 (*Minimum 125)
05	SAE	Standard	Locking	WC-2021-(Stroke + 25*)-R2 (*Minimum 125)
06	G	Standard	Locking	WC-2037-(Stroke + 25*)-R2 (*Minimum 125)
07	NPT	Duplex	Non-Locking	WC-2042-(Total Stroke + 13)-(Sub Stroke + 7.5)-R2
08	SAE	Duplex	Non-Locking	WC-2043-(Total Stroke + 13)-(Sub Stroke + 7.5)-R2
09	G	Duplex	Non-Locking	WC-2044-(Total Stroke + 13)-(Sub Stroke + 7.5)-R2
10	NPT	Duplex	Locking	WC-2045-(Total Stroke + 13)-(Sub Stroke + 7.5)-R2
11	SAE	Duplex	Locking	WC-2046-(Total Stroke + 13)-(Sub Stroke + 7.5)-R2
12	G	Duplex	Locking	WC-2047-(Total Stroke + 13)-(Sub Stroke + 7.5)-R2

Stroke Notes

The first stroke in slide part number is the Sub Stroke. Second stroke is the Total Stroke = sum of the two strokes. Some cylinders have a minimum stroke. For shorter stroke slides order the Minimum stroke cylinder.

Examples:

Slide unit R200007001A0000P0W: Order cylinder WC-2018-225-R2
 Slide unit R208528507A0000P0W: Order cylinder WC-2042-383-92.5-R2

CYLINDER SEAL MAINTENANCE

Seals should be replaced routinely to avoid cylinder failure. Please have cylinder model information and/or Welker job number ready when ordering seal kits or repair kits. This information is located on the unit's tag and on the cylinder.

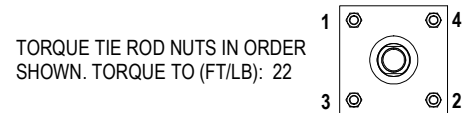
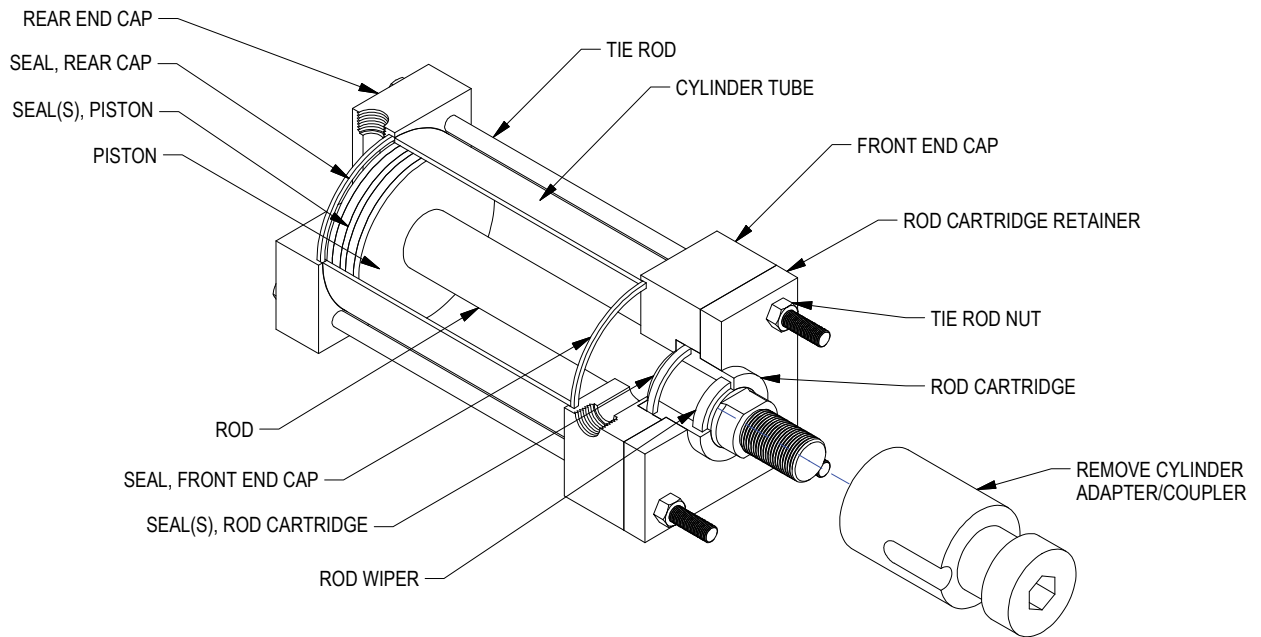

TO REPLACE THE ROD CARTRIDGE SEALS

1. Remove cylinder coupler/adapter. Coupler adapter is affixed to cylinder rod with permanent Loctite. To remove, first extend the cylinder rod to move the coupler adapter away from cylinder body. Then apply heat to the coupler to soften the thread locker. Use caution so as not to overheat the cylinder rod seals!
2. Remove the tie rod nuts.
3. Remove the rod cartridge retainer.
4. Remove the rod bearing cartridge from the front end cap by pulling straight out while twisting slightly.
5. Remove the rod wiper, the rod seal and the rod cartridge O-ring seal. It is very important to note the orientation of the rod wiper and the rod seal in the seal grooves. The new seals must be oriented the exact same way during replacement.
6. Clean the rod bearing cartridge and inspect for it for excessive wear or scoring. Replace the rod bearing cartridge if necessary.
7. Install a new rod wiper, rod seal, and rod cartridge O-ring seal into the rod bearing cartridge. Coat the I.D. of the rod bearing cartridge with Acrolube grease.
8. Check the piston rod end for burrs in the thread areas and wrench flats. Remove and polish sharp edges as required.
9. Install the reassembled rod cartridge assembly over the piston rod end with a slight twisting motion. Push the rod cartridge assembly into the bored cavity in the front end cap.
10. Install the rod cartridge retainer.
11. Install tie rod nuts, hand tighten then torque to the values shown. Use MoS2 grease or equivalent on both the threads and bearing surface. Should lubricant not be available, torque values should be increased by 50%.

SHOCK ABSORBER REPLACEMENT

1. Lockout slide to prevent motion.
2. Remove jam nut from shock absorber
3. Unscrew shock absorber from installation.
4. Install new shock absorber. Set the shock absorber so that it is fully compressed when the slide is against it then back it off 1/32".
5. Tighten jam nut.

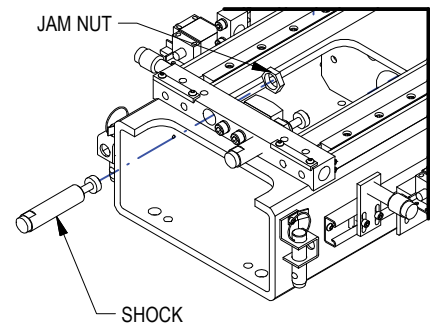

REPLACING KEVLAR SHROUD

1. Lockout slide to prevent motion.
2. Remove shroud keepers, in two locations (per side).
3. Remove shroud.
4. Install new shroud around shroud guides, as shown.
5. Clamp shroud in place with one keeper. Tension shroud with pliers. Tighten second keeper.

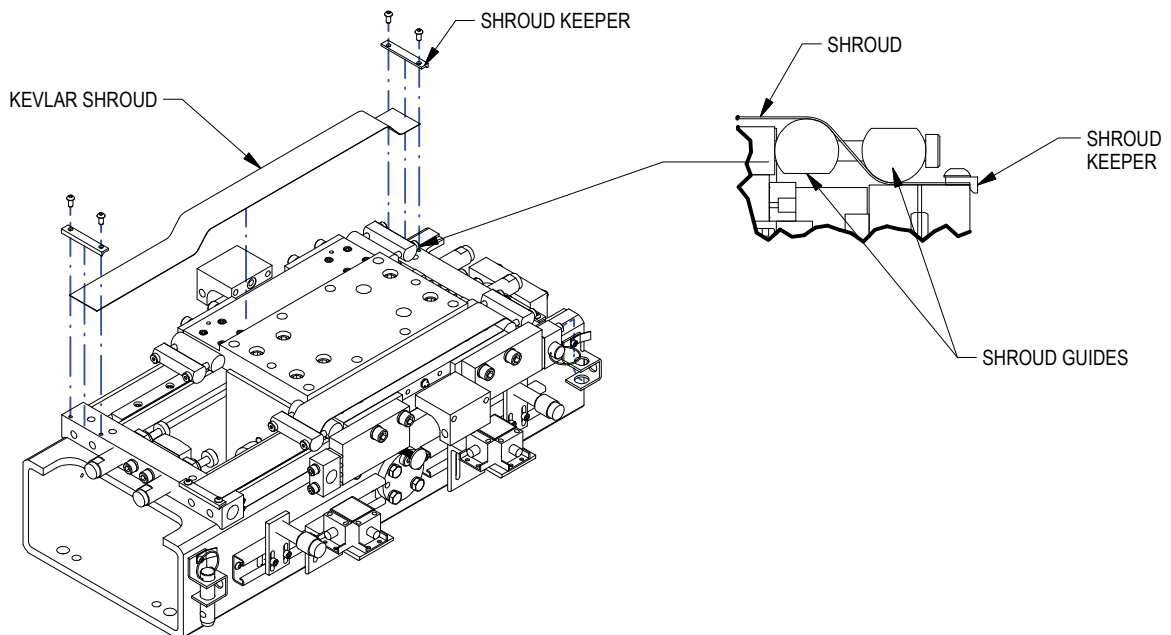

BEARING & RAIL REPLACEMENT

1. Release air pressure from system. Secure slide with lockout pin to prevent motion.
2. Remove top shrouds (see sheet 7).
3. Remove bolts and lockwashers from all bearings (4 bolts per bearing, 4 bearings) at carriage plate.
4. Remove (4) bolts that fasten carriage plate to drive bracket.
5. Disconnect grease hoses from bearings and carefully lift carriage plate up and away from slide.
6. Remove the screw cover plugs from the rail that is going to be replaced.
7. Remove bolts that anchor rail to base plate. Slide bearing assembly out of the way for bolt access as needed.
8. Remove rail and bearing assembly. Remove cam screws. Clean base plate and debris from rail pocket.
9. Set new rail/bearing assembly in place, being careful to keep the bearings on the rail at all times! The internal balls may become dislodged from the bearing block.
10. Reinstall the cam screws that hold the rail against dowels or machined edge. Install bolts in the new rail so that the rail is making light contact with the base plate, sliding bearings as needed for access. Do not tighten!
11. Tighten with just enough force to hold the rail firmly. Do not over-tighten.
12. Tighten rail bolts using torque wrench, working from the center of the rail to the ends. Torque to 22.4 lb ft. (3040 N-cm)
13. Install plugs in bolt holes so top of plug is flush with rail.
14. Align carriage plate. Reattach grease hoses to bearings.
15. Install bearing bolts and lock washers, following the sequence in diagram below. Tighten to torques in chart. Use removable thread adhesive on all bolts.
16. Bolt carriage plate to drive bracket. Install top shrouds.
17. Grease bearings, see Bearing Lubrication, sheet 9

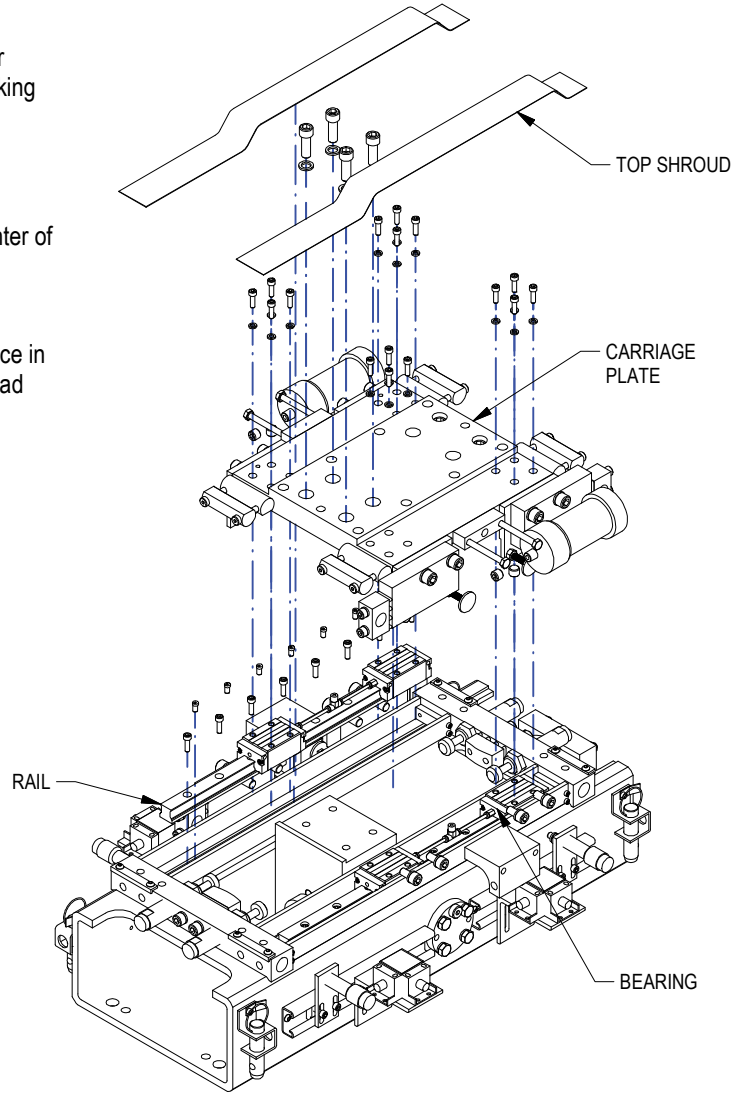
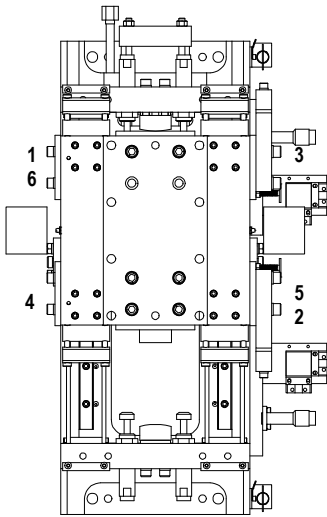

Tightening Torques for Metric Bolts (dry)				
Size	Steel		Aluminum	
M5	10.0 Nm	7.4 ft lb.	5.0 Nm	3.7 ft lb.
M6	19.0 Nm	14.0 ft lb.	9.5 Nm	7.0 ft lb.
M8	45.0 Nm	33.2 ft lb.	22.5 Nm	16.6 ft lb.
M10	89.0 Nm	65.6 ft lb.	44.5 Nm	32.8 ft lb.
M12	156.0 Nm	115.1 ft lb.	78.0 Nm	57.5 ft lb.

BEARING LUBRICATION

Rail bearings require lubrication for long life, frequency depends upon usage and environment. Manual lubrication is recommended every six months.

MANUAL LUBRICATION FOR UNITS WITHOUT AUTO-LUBE OPTION:

1. Secure slide with lockout pin.
2. Lube ports are located on either side of the carriage plate, standard 1/8" NPT grease fitting.
3. Apply 1.1 cubic centimeters of grease per cartridge.
Mobil XHP 222 is recommended.

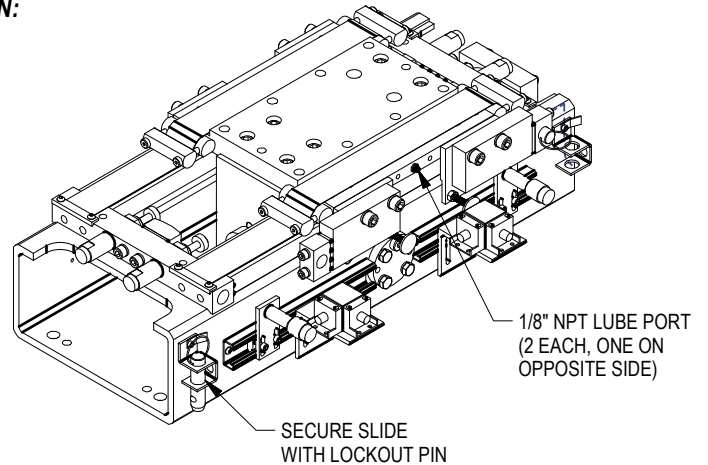

AUTO LUBE CARTRIDGE REPLACEMENT

The auto lube option is a cost effective alternative, requiring no tools or assembly. Simply replace cartridge when empty:

1. Secure the slide with lockout pin.
2. Unscrew the auto lube assembly from the slide port, leaving adapter in place. Remove the protective cover from the empty unit. Unscrew the control unit from the empty cartridge, turning it counterclockwise. The unit will automatically shut off, saving all settings.
3. Remove protective cover from the new cartridge.
4. Place the control unit on the cartridge and turn clockwise until the raised edge on the control unit lines up with the arrow mark on the cartridge. The unit is correctly assembled when the display shows the pre-programmed frequency setting.
5. Remove the black outlet plug on the unit and screw the activated unit into the adapter's port. Place the protection cover back on the control unit.
6. The empty cartridge contains a battery. Please follow the waste disposal regulations in your area.

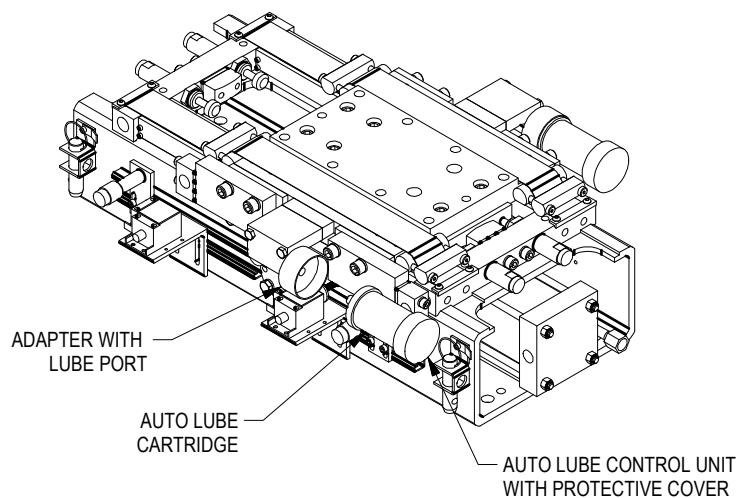

TO REPLACE WELKER SMART STOP

There are four (4) LED lights on the Smart Stop's cable end: (2) green power-on lights and (2) yellow switch engagement lights. When lights fail, replace switch.

1. Release air pressure from system. Locate carriage plate to access Smart Stop, secure slide with lockout pin to prevent motion.
2. Disconnect cable.
3. Remove (2) socket head cap screws from Smart Stop. Remove old Smart Stop and Shims.
4. Clean block location surface.
5. Install new Smart Stops using (2) socket head cap screws. Be sure cable is in the proper orientation. Be sure to replace shims!
6. Reconnect cable.

