

EXPANDING LOCATING PIN

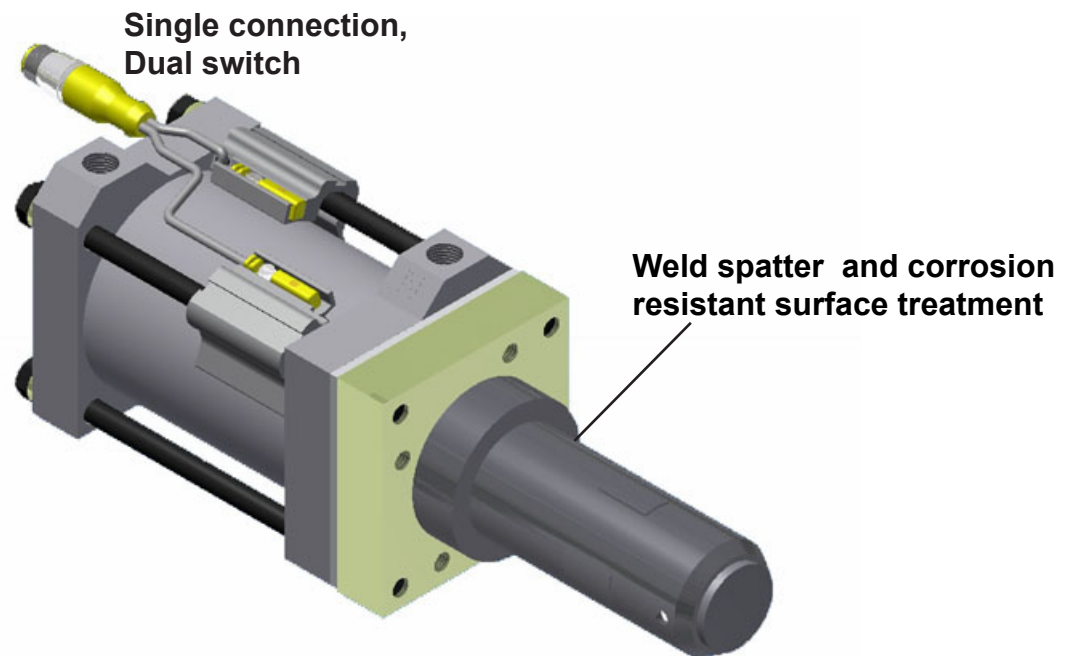

Welker Expanding pin is able to center loose tolerance diameters in tubes or plates.

Capable of locating large and heavy fabrications.

Provides for easy load and unload of work piece.

Two or four finger designs available.

Improves process control, quality and throughput.

Engineered to specific application requirements.

WELKER EXPANDING PIN

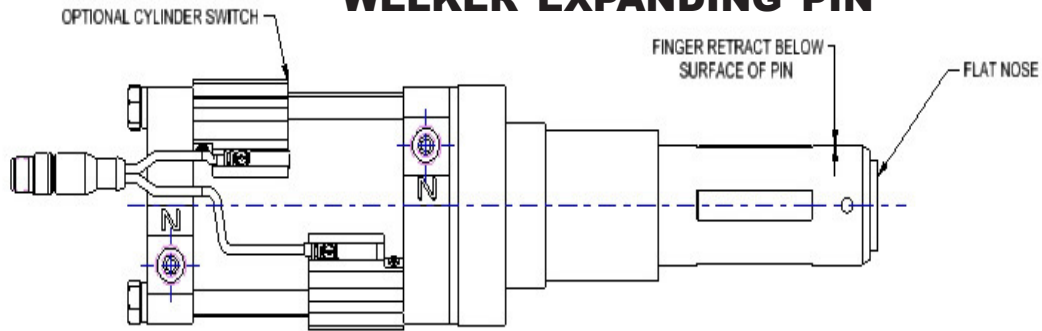

VIEW SHOWN WITH FINGERS RETRACTED

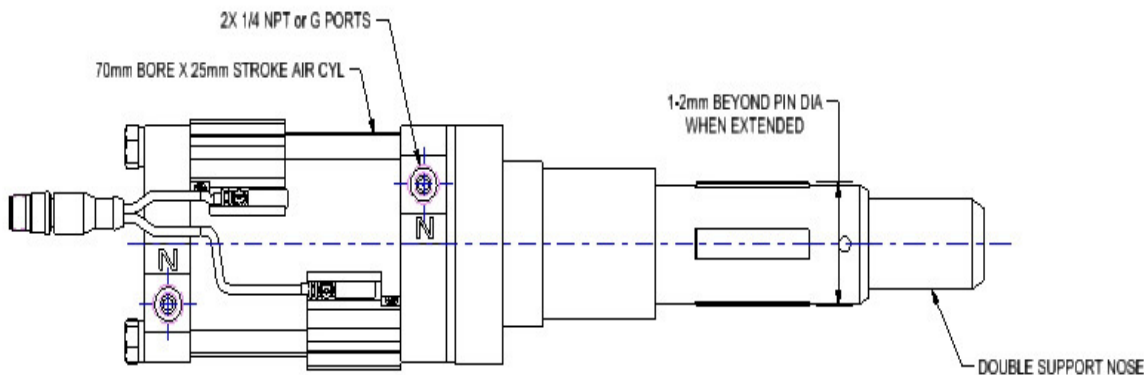

VIEW SHOWN WITH FINGERS EXTENDED

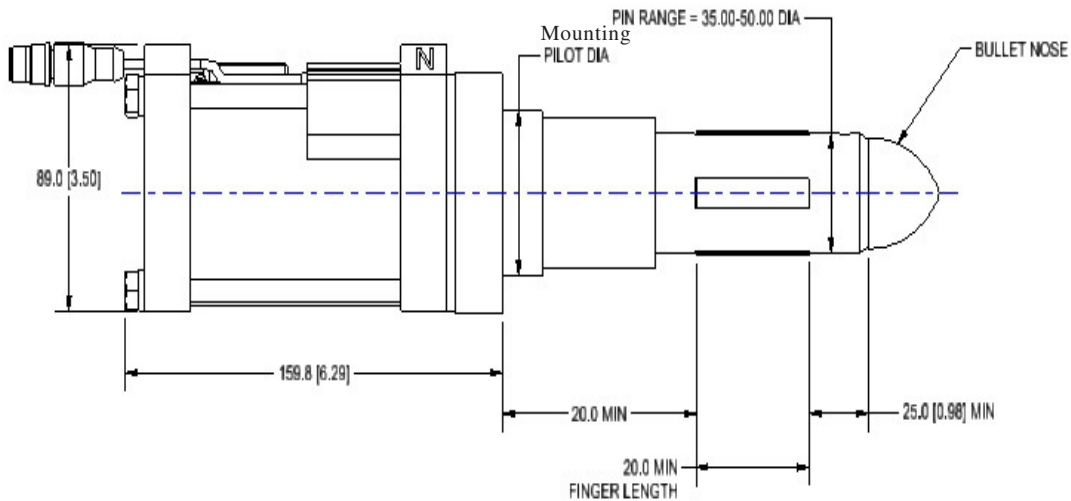

APPLICATION WORKSHEET

S.O # _____ Date: _____

1. PIN DIAMETER _____

2. FINGER LENGTH _____

3. HORIZONTAL OR VERTICAL H V

4. ENVIRONMENTAL CONDITIONS

5. NOSE STYLE _____

6. FINGERS ORIENTED 45° FROM WELDING

7. MOUNTING BRACKET DESIRED Y N

CUSTOMER INFORMATION

1. I.D. DIAMETER _____

2. I.D. TOLERANCE _____

3. PART WEIGHT _____

4. ENGAGED LENGTH _____

5. IF WELDING DIRECTLY ON BUSHING OR PART HELD BY EXPANDING PIN USE DBL.ROD TO CONTROL INITIAL PRESSURE AND CLEARANCE _____