

LP SERIES RAIL SLIDES

STROKES UP TO 495mm
STANDARD NON-LOCK OR ROD LOCK* PNEUMATIC CYLINDERS

LPM

250 LB LOAD CAPACITY

50mm BORE PNEUMATIC CYLINDER
15-SERIES SQUARE RAIL BEARINGS

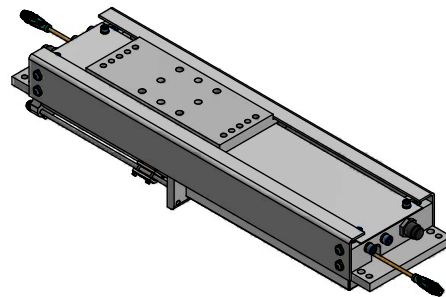

LP1

250 LB LOAD CAPACITY

50mm BORE PNEUMATIC CYLINDER
15-SERIES SQUARE RAIL BEARINGS

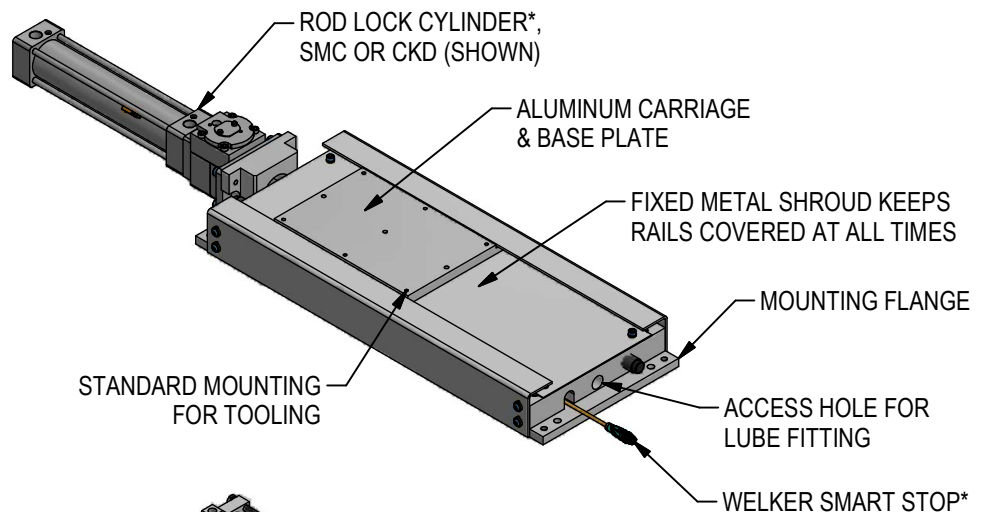

LP2

500 LB LOAD CAPACITY

70mm BORE PNEUMATIC CYLINDER
25-SERIES SQUARE RAIL BEARINGS

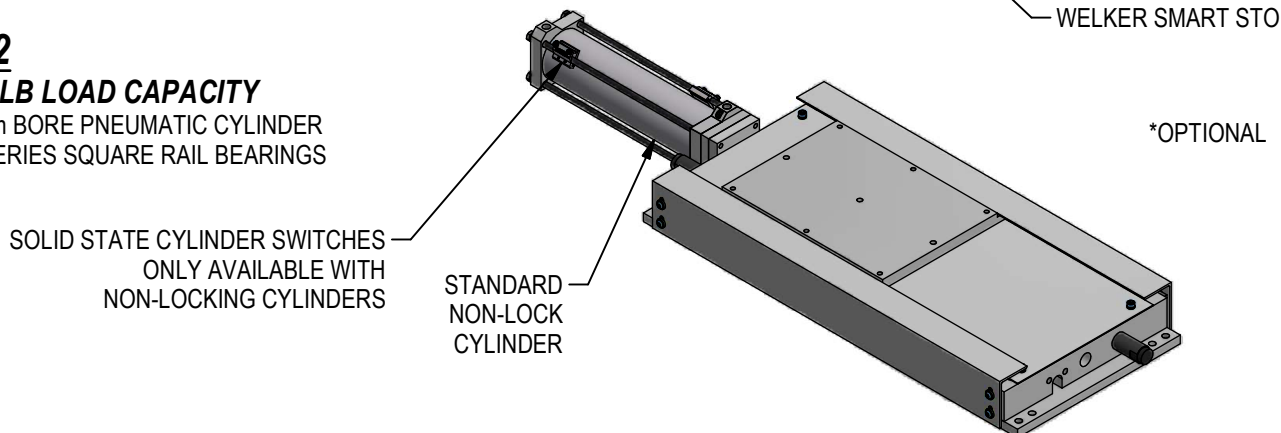

RELEASED 9/27/2023

ORDERING INFORMATION

NOTE: ALL BOXES MUST BE FILLED IN FOR A COMPLETE PART NUMBER

			0	0	0												W
--	--	--	---	---	---	--	--	--	--	--	--	--	--	--	--	--	---

Series

- LPM
- LP1
- LP2

Stroke

135 075, 135, 195, 255, 315, 375, 435, 495mm

Actuator

- 01** Cylinder with NPT Ports
- 02** Cylinder with G Ports
- 03** SMC Cylinder with Rod Lock, NPT Ports
- 04** SMC Cylinder with Rod Lock, G Ports
- 05** CKD Cylinder with Rod Lock, NPT Ports
- 06** CKD Cylinder with Rod Lock, G Ports

Port Location

See Dimensional Drawings for Allowable Positions

- A** Ports @ X1
- B** Ports @ X2
- C** Ports @ X3
- D** Ports @ X4

Retract Shims: Whole mm

Retract Shims: Quarter mm

Extend Shims: Whole mm

Extend Shims: Quarter mm

See Shim Chart Coding below

Switch Options

- 00** No Switch
- LX** Cylinder Switch*
See chart below
*ONLY available with Actuator 01/02

Stop Options

- X** NAAMS Stop
- P** Welker Smart Stop

SHIM CHART									
WHOLE MILLIMETER CODES								QUARTER MM CODES	
THK (mm)	CODE	THK (mm)	CODE	THK (mm)	CODE	THK (mm)	CODE	THK (mm)	CODE
0	0	8	8	16	G	24	R	0.00	0
1	1	9	9	17	H	25	S	0.25	A
2	2	10	A	18	J	26	T	0.50	B
3	3	11	B	19	K	27	U	0.75	C
4	4	12	C	20	L	28	V		
5	5	13	D	21	M	29	W		
6	6	14	E	22	N	30	X		
7	7	15	F	23	P	35	Y		

Shimming for slides is available to quarter millimeter increments. Select whole and quarter mm sizes from codes shown on chart. For increment sizes not shown, order a larger shim and machine to desired size. Example: For a 0.62mm shim order 0.75 shim, machine to 0.62.

Examples:
16.25mm shim = GA
24.00mm shim = R0
10.50mm shim = AB
05.75mm shim = 5C

Switch	Part Number	Manufacturer	Description
L3	SWITCH L3** L3 switch is weld field immune, comparable to World Switches	Welker	4-Wire, 4-Pin, DC (PNP) M12 X 1 Quick Disconnect
L5	MK5113	ifm Efelector	3-Wire, 4-Pin, DC (NPN) M12 X 1 Quick Disconnect

Standard Switch Option - All other options may affect price and delivery

SWITCHES ON LP SLIDES ARE SINGLE-SENSOR: TWO SWITCHES ARE INSTALLED PER CYLINDER.
*Cylinder switches only available with Actuators 01/02. Switches for Actuators 03/04 and 05/06 are customer supplied ~ contact SMC, CKD.
**Note that some mid and low frequency DC resistance applications (i.e. aluminum resistance welding applications) may cause a fault. In these applications, it is recommended that the sensor be ignored or bypassed during the welding cycle.

ALL DIMENSIONS ARE MILLIMETERS
UNLESS OTHERWISE NOTED
DO NOT SCALE DRAWING



LPM GENERAL DIMENSIONS

NOTE FOR ALL CUSTOMER FASTENERS: FASTENERS MUST NOT EXCEED 15mm DEPTH IN CARRIAGE PLATE

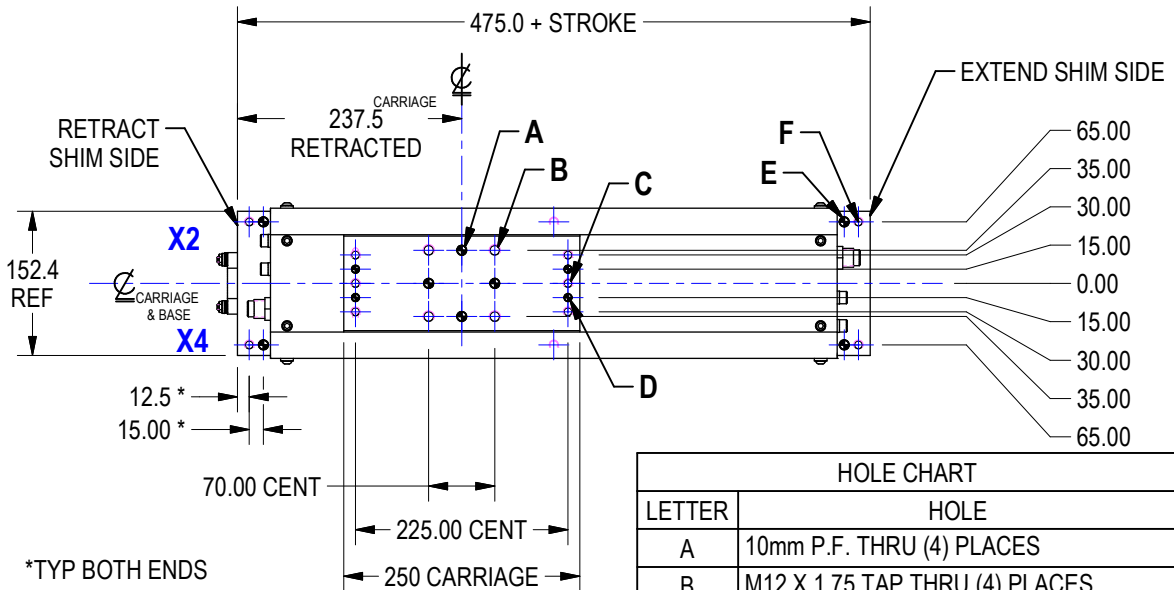

SEE VIEW A
(BELOW)

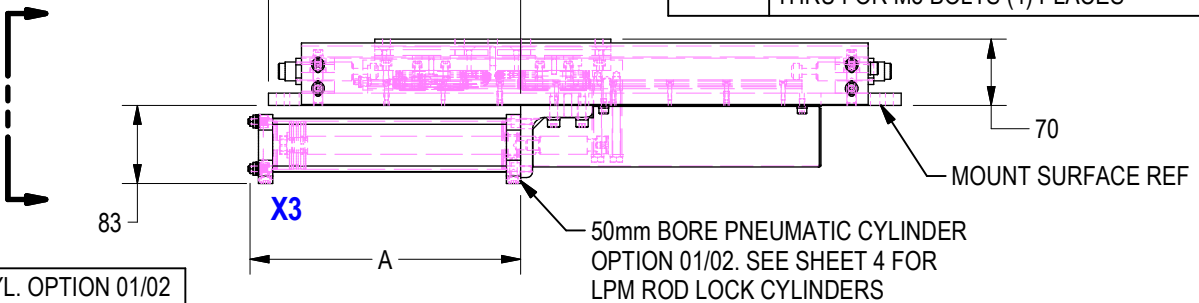

CYL. OPTION 01/02	
STROKE	DIM A
75	169
135	229
195	289
255	349
315	409
375	469
435	529
495	589

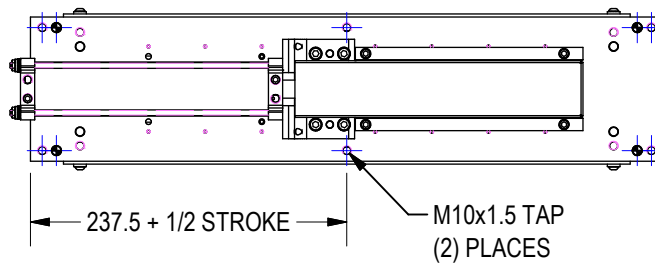

VIEW A:

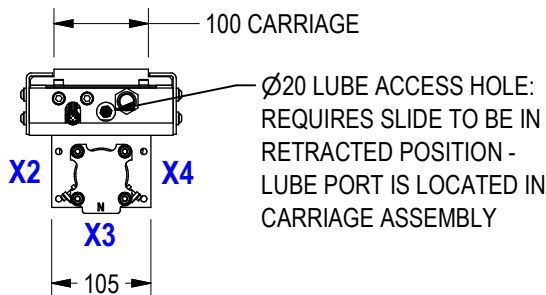

ALLOWABLE PORT LOCATIONS
ACTUATOR 01/02

SHEET 3

NOTE: THIS UNIT HAS NO SUPPLIED LOCKOUT DETAILS. ANY LOCKOUT REQUIREMENTS ARE TO BE SUPPLIED BY THE CUSTOMER.

ALL DIMENSIONS ARE MILLIMETERS
UNLESS OTHERWISE NOTED
DO NOT SCALE DRAWING

WELKER
ENGINEERED PRODUCTS
800-229-0890 welkerproducts.com

LPM ROD LOCK CYLINDERS

SMC (SERIES CDNA2) ROD LOCK CYLINDER

OPTIONS 03/04

ALLOWABLE PORT LOCATIONS
ACTUATOR 03/04

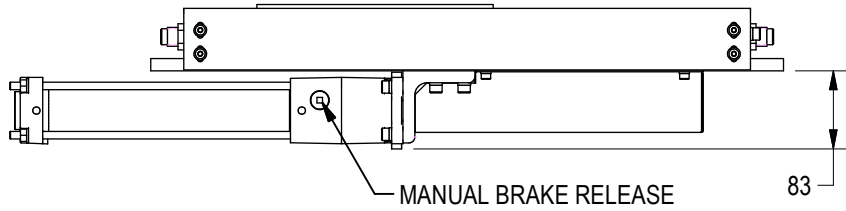
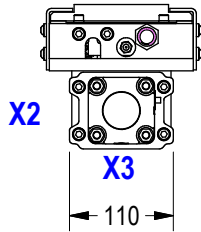

CYL OPTION 03/04	
STROKE	DIM A
75	291
135	366
195	416
255	466
315	541
375	591
435	666
495	716

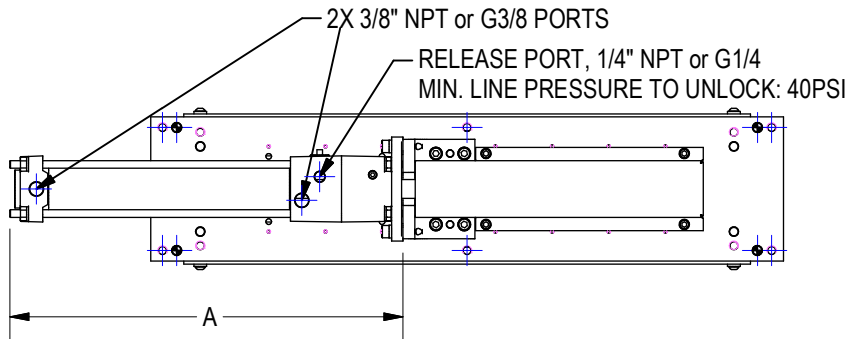

CKD (JSG SERIES) ROD LOCK CYLINDER

OPTIONS 05/06

ALLOWABLE PORT LOCATIONS
ACTUATOR 05/06

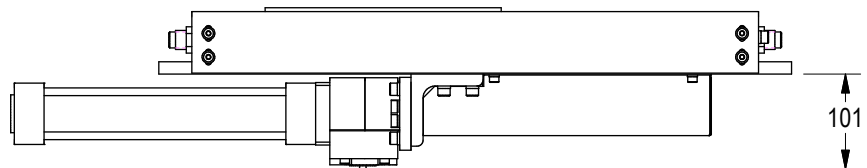
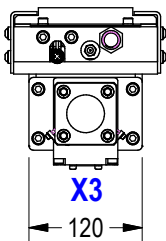

CYL OPTION 05/06	
STROKE	DIM A
75	299
135	374
195	424
255	474
315	549
375	599
435	674
495	724

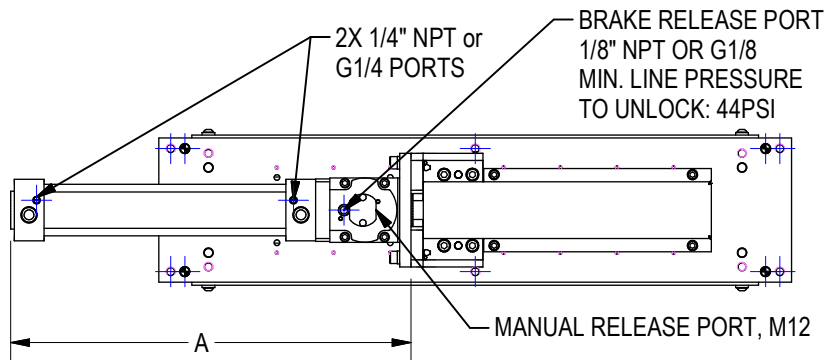

CYLINDER SWITCHES ARE CUSTOMER SUPPLIED, CONTACT SMC OR CKD.

ALL DIMENSIONS ARE MILLIMETERS
UNLESS OTHERWISE NOTED
DO NOT SCALE DRAWING

WELKER
ENGINEERED PRODUCTS
800-229-0890 welkerproducts.com

LP1 GENERAL DIMENSIONS

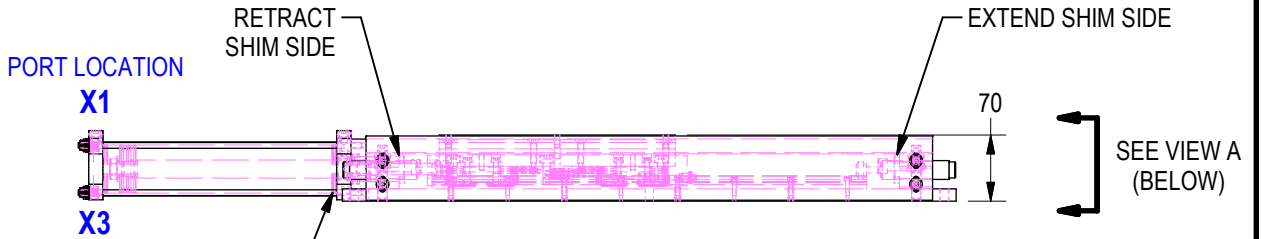
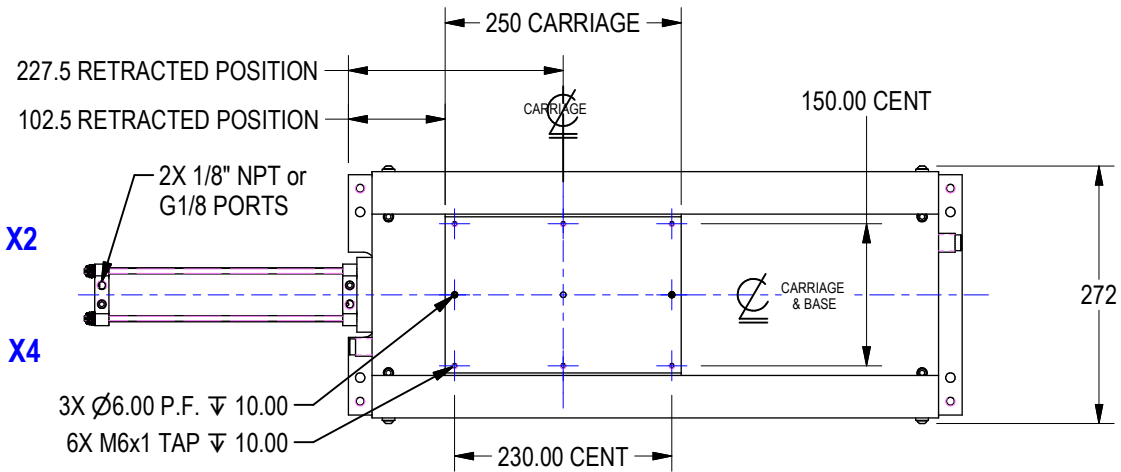

50mm BORE PNEUMATIC CYLINDER OPTION 01/02. SEE SHEET 6 FOR LP1 ROD LOCK CYLINDERS

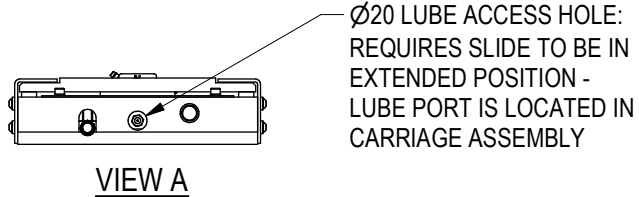
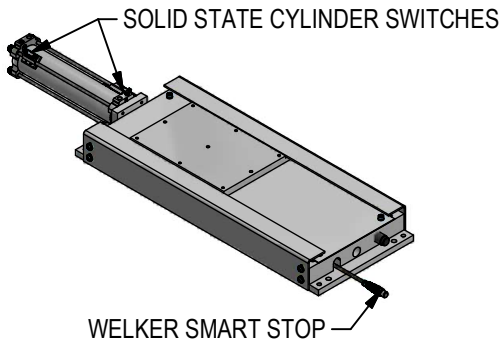
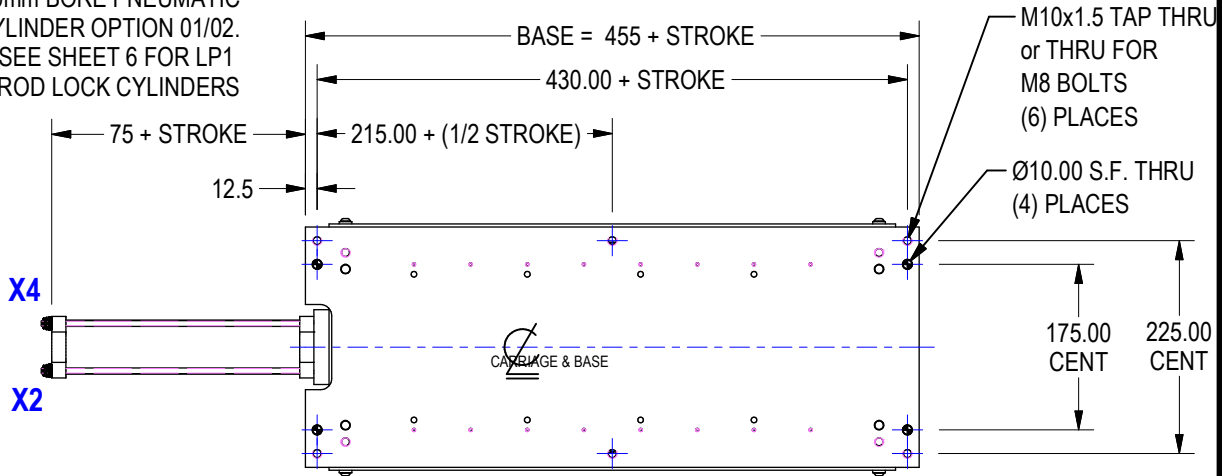

ALL DIMENSIONS ARE MILLIMETERS UNLESS OTHERWISE NOTED DO NOT SCALE DRAWING

NOTE: THIS UNIT HAS NO SUPPLIED LOCKOUT DETAILS. ANY LOCKOUT REQUIREMENTS ARE TO BE SUPPLIED BY THE CUSTOMER.

WELKER
ENGINEERED PRODUCTS
800-229-0890 welkerproducts.com

LP1 ROD LOCK CYLINDERS

SMC (SERIES CDNA2) ROD LOCK CYLINDER OPTIONS 03/04

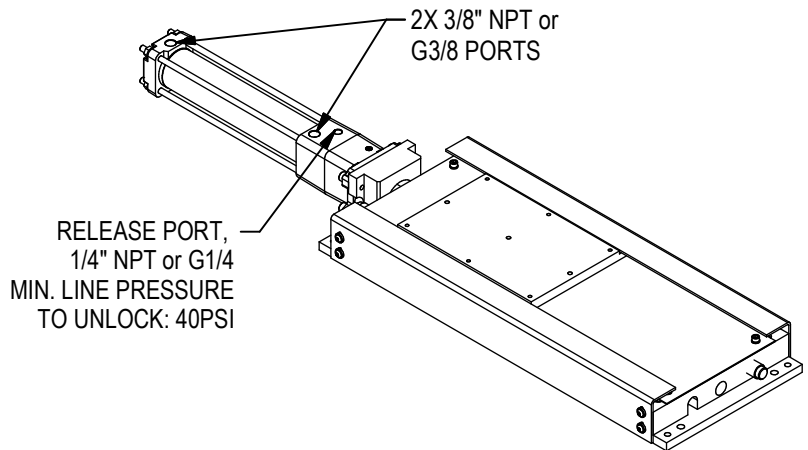

ALLOWABLE PORT LOCATIONS ACTUATOR 03/04

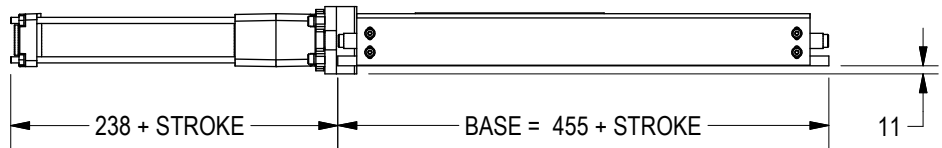
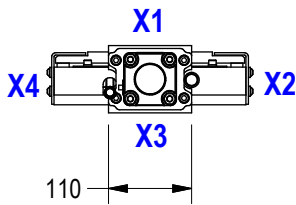

CKD (JSG SERIES) ROD LOCK CYLINDER OPTIONS 05/06

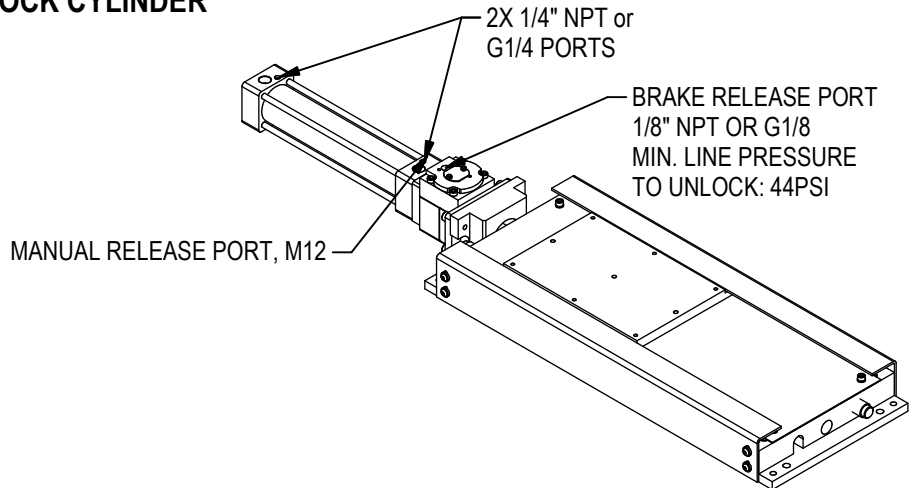

ALLOWABLE PORT LOCATIONS ACTUATOR 05/06

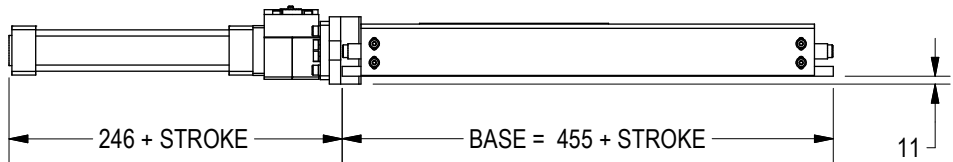
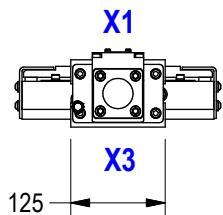

ALL DIMENSIONS ARE MILLIMETERS
UNLESS OTHERWISE NOTED
DO NOT SCALE DRAWING

WELKER
ENGINEERED PRODUCTS
800-229-0890 welkerproducts.com

LP2 GENERAL DIMENSIONS

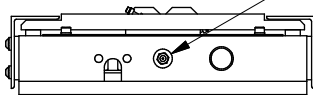
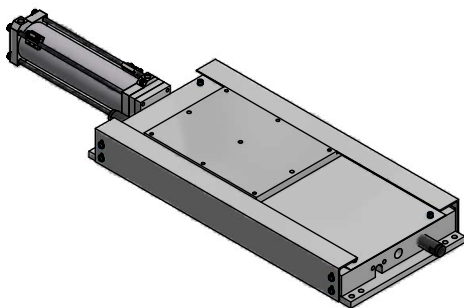
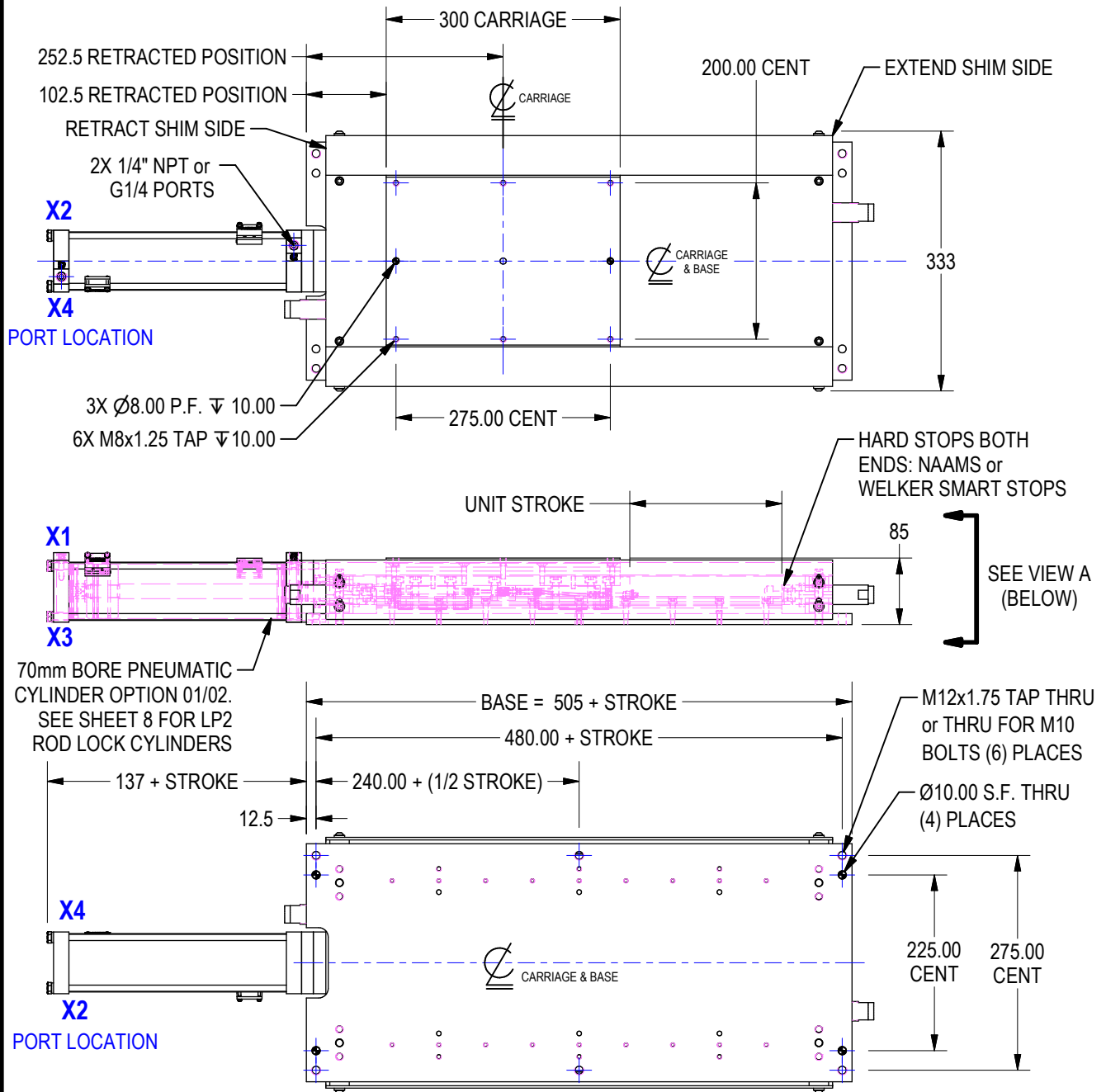

VIEW A

Ø20 LUBE ACCESS HOLE:
 REQUIRES SLIDE TO BE IN
 EXTENDED POSITION -
 LUBE PORT IS LOCATED IN
 CARRIAGE ASSEMBLY

ALL DIMENSIONS ARE MILLIMETERS
 UNLESS OTHERWISE NOTED
 DO NOT SCALE DRAWING

 ENGINEERED PRODUCTS
 800-229-0890 welkerproducts.com

NOTE: THIS UNIT HAS NO SUPPLIED LOCKOUT DETAILS. ANY LOCKOUT
 REQUIREMENTS ARE TO BE SUPPLIED BY THE CUSTOMER.

LP2 ROD LOCK CYLINDERS

SMC (SERIES CDNA2) ROD LOCK CYLINDER OPTIONS 03/04

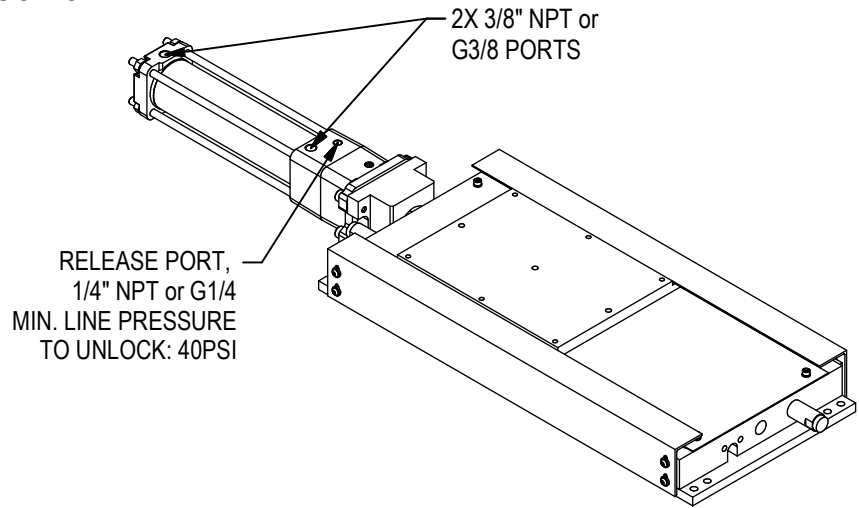

ALLOWABLE PORT LOCATIONS ACTUATOR 03/04

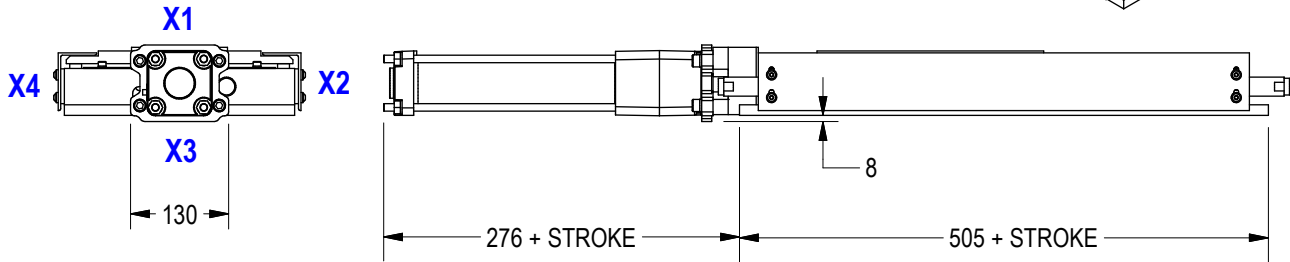

CKD (JSG SERIES) ROD LOCK CYLINDER OPTIONS 05/06

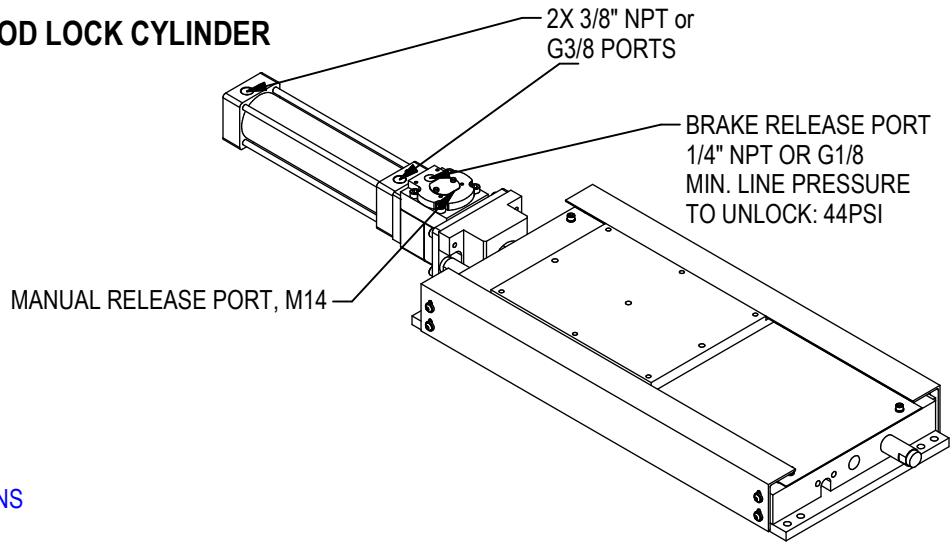

ALLOWABLE PORT LOCATIONS ACTUATOR 05/06

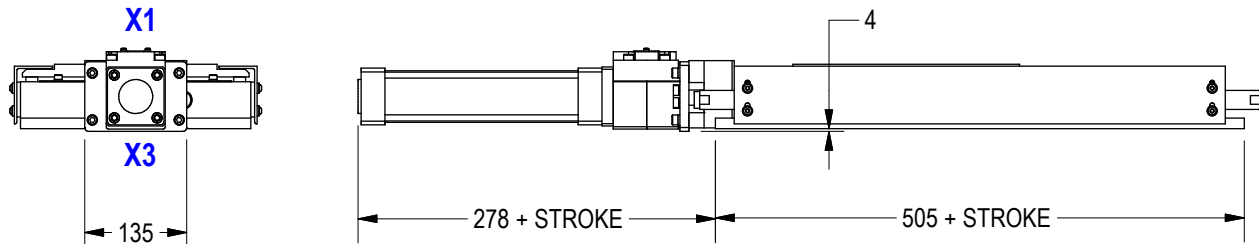

ALL DIMENSIONS ARE MILLIMETERS
UNLESS OTHERWISE NOTED
DO NOT SCALE DRAWING

WELKER
ENGINEERED PRODUCTS
800-229-0890 welkerproducts.com

WELKER SMART STOP

WELKER SMART STOP does all stopping & sensing functions in one part.
SMART STOP minimizes engineering, field set up and operator adjustment time.

WELKER SMART STOP eliminates:

- Need for separate mounts, brackets & flags.
- Need for switch adjustments when shimming.
- Improper adjustment of outboard switches.
- Outboard switch vibrating loose in bracket.
- Protecting outboard proxies from being stepped on or bent in tools.

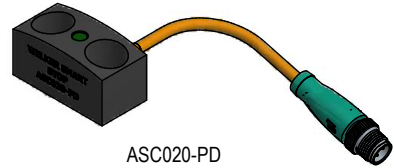

ASC020-PD

MODEL NO:
 ASC020-PD FOR CROWNED, DRILL & C'BORE FOR M10 SHCS + DC SWITCH

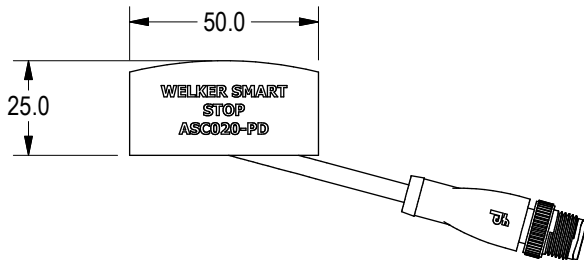

SPECIFICATIONS

General Specifications

Switching function	Normally Open (NO)
Output type	PNP
Rated operating distance, sn	1.75mm
Output polarity	DC
Assured operating distance sa	0 - 1.42 mm
Output type	3-wire

Nominal Ratings

Operating voltage, U_B	5 - 30 V DC
Switching frequency, f	0 - 6000 Hz
Reverse polarity protection	Reverse polarity protected
Short-circuit protection	Pulsing
Voltage drop, U_d	≤ 1.5 V
Operating current, I_L	0 - 100 mA
Off-state current, I_r	0 - 0.2 mA
No-load supply current, I_0	≤ 15 mA

Indicators/Operating Means

Operating voltage indicator	LED green
Switching state indicator	LED yellow

Ambient Conditions

Ambient temperature	-40 - 85 °C (-40 - 185 °F)
Storage temperature	-40 - 85 °C (-40 - 185 °F)

Mechanical Specifications

Connection type Connector plug	M12 x 1 , 4-pin
Cable length	255mm
Degree of protection	IP67
Cable material	Weld spatter resistant, robotic quality POC
Cable color	Orange

WIRING DIAGRAM (PNP)

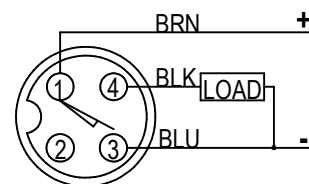

ALL DIMENSIONS ARE MILLIMETERS
 UNLESS OTHERWISE NOTED
 DO NOT SCALE DRAWING



LPM SLIDE ACCURACY

POSITIONAL ACCURACY specifies the allowable deviation between the nominal position of a reference point on the carriage (D1 as shown) to the actual position that is achieved.

TRAVEL ACCURACY specifies the allowable deviation along the plane of motion of a reference point on the carriage (D1 as shown) to the actual position *during movement* - in other words, the allowable side-to-side movement (in the direction of Y) and up-and-down movement (in the direction of Z) as the unit travels.

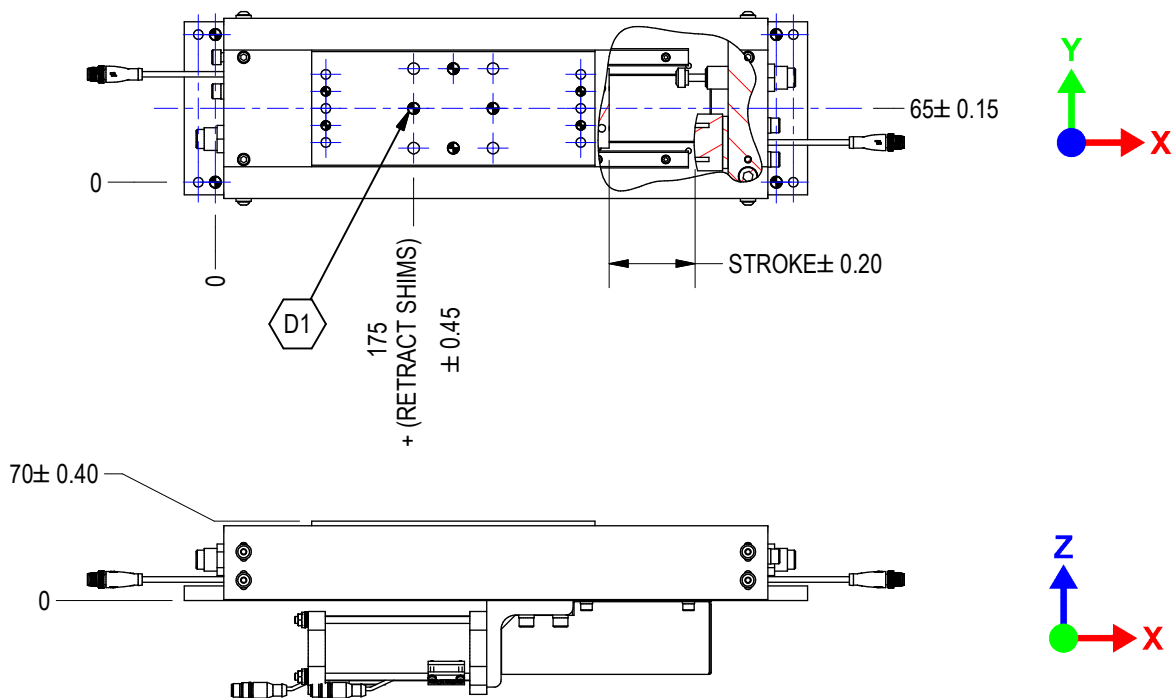

TRAVEL ACCURACY (RUNOUT)	
Y-DIRECTION	Z-DIRECTION
0.15	0.15

ALL DIMENSIONS ARE MILLIMETERS
UNLESS OTHERWISE NOTED
DO NOT SCALE DRAWING

WELKER
ENGINEERED PRODUCTS
800-229-0890 welkerproducts.com

LPM PAYLOAD v. Y-OFFSET CAPACITY

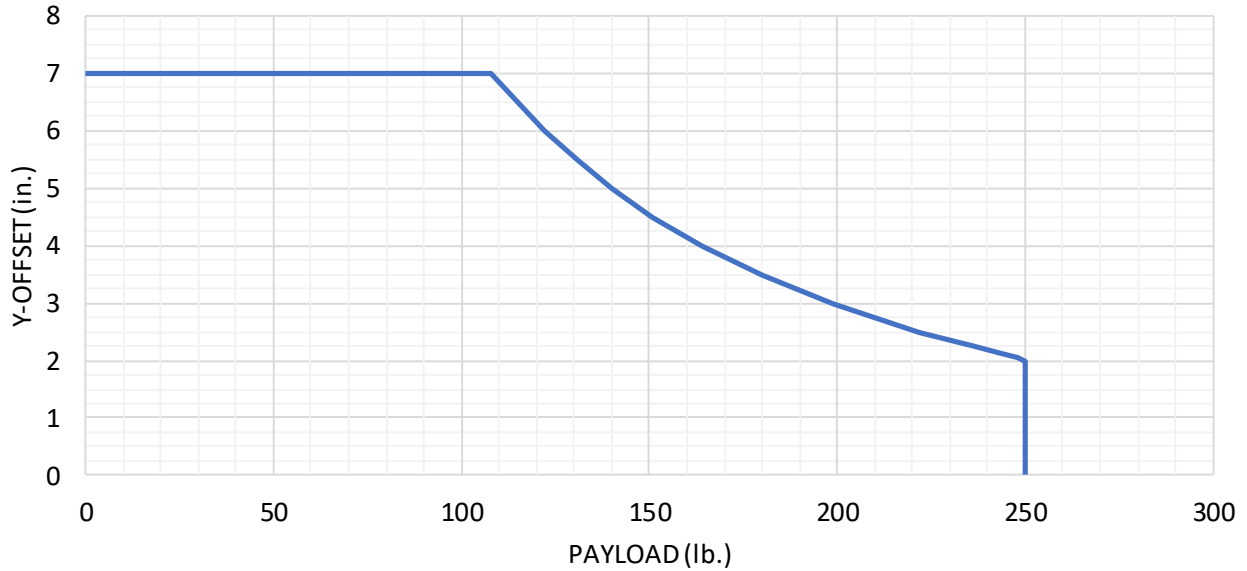

LPM PITCH ANGLE v. PAYLOAD CAPACITY

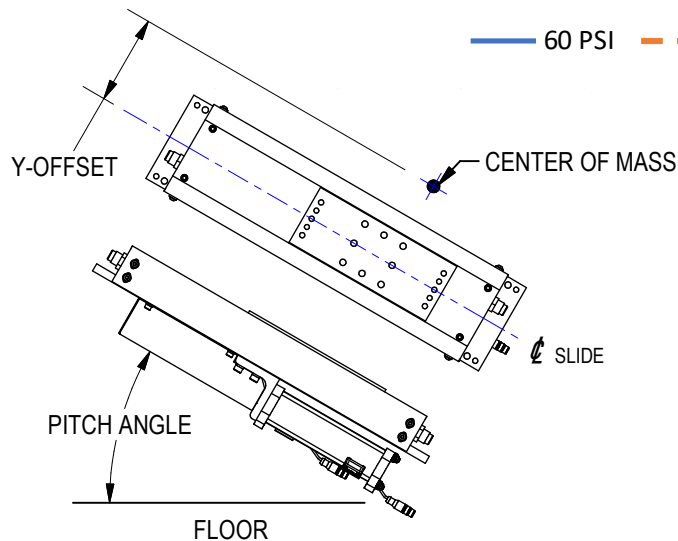
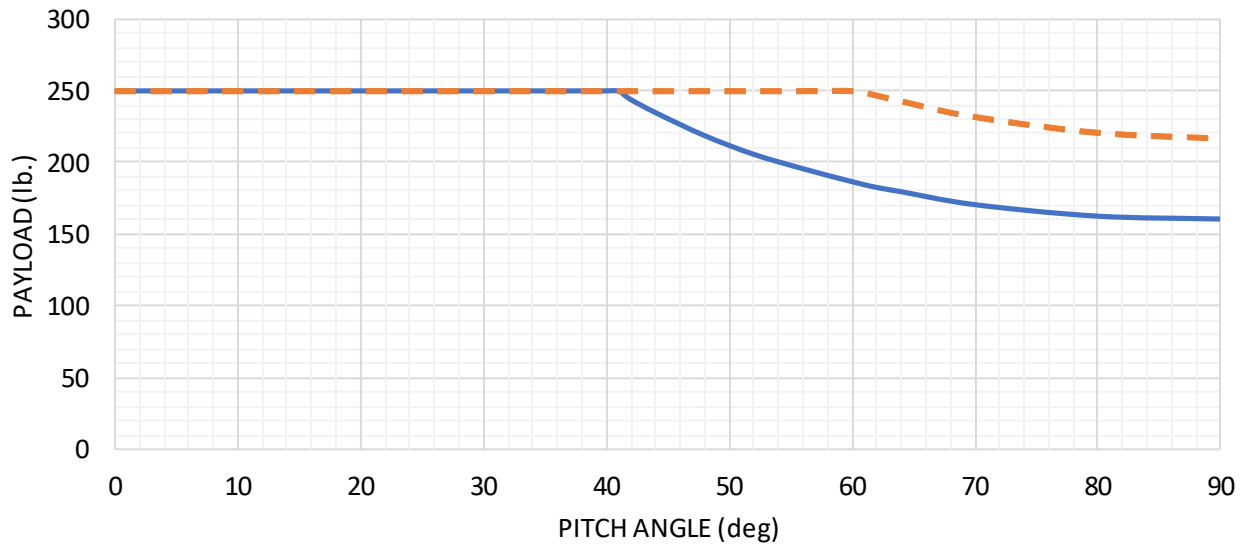

— 60 PSI — 80 PSI

When using these graphs, applications are evaluated on two separate criteria: payload v. offset and pitch angle v. payload. An approved application meets both criteria. For applications outside the graph safety zone, contact Welker.

ALL DIMENSIONS ARE MILLIMETERS
UNLESS OTHERWISE NOTED
DO NOT SCALE DRAWING

WELKER
ENGINEERED PRODUCTS
800-229-0890 welkerproducts.com

LP1 SLIDE ACCURACY

POSITIONAL ACCURACY specifies the allowable deviation between the nominal position of a reference point on the carriage (D1 as shown) to the actual position that is achieved.

TRAVEL ACCURACY specifies the allowable deviation along the plane of motion of a reference point on the carriage (D1 as shown) to the actual position *during movement* - in other words, the allowable side-to-side movement (in the direction of Y) and up-and-down movement (in the direction of Z) as the unit travels.

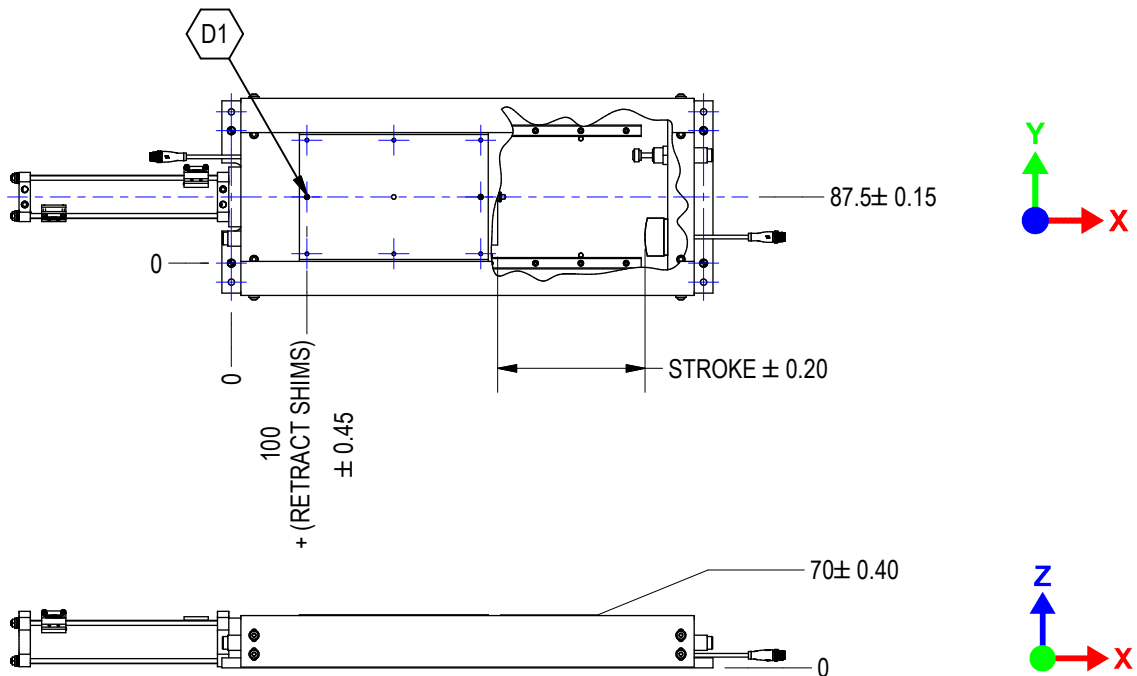

TRAVEL ACCURACY (RUNOUT)	
Y-DIRECTION	Z-DIRECTION
0.15	0.15

ALL DIMENSIONS ARE MILLIMETERS
UNLESS OTHERWISE NOTED
DO NOT SCALE DRAWING

WELKER
ENGINEERED PRODUCTS
800-229-0890 welkerproducts.com

LP1 PAYLOAD v. Y-OFFSET CAPACITY

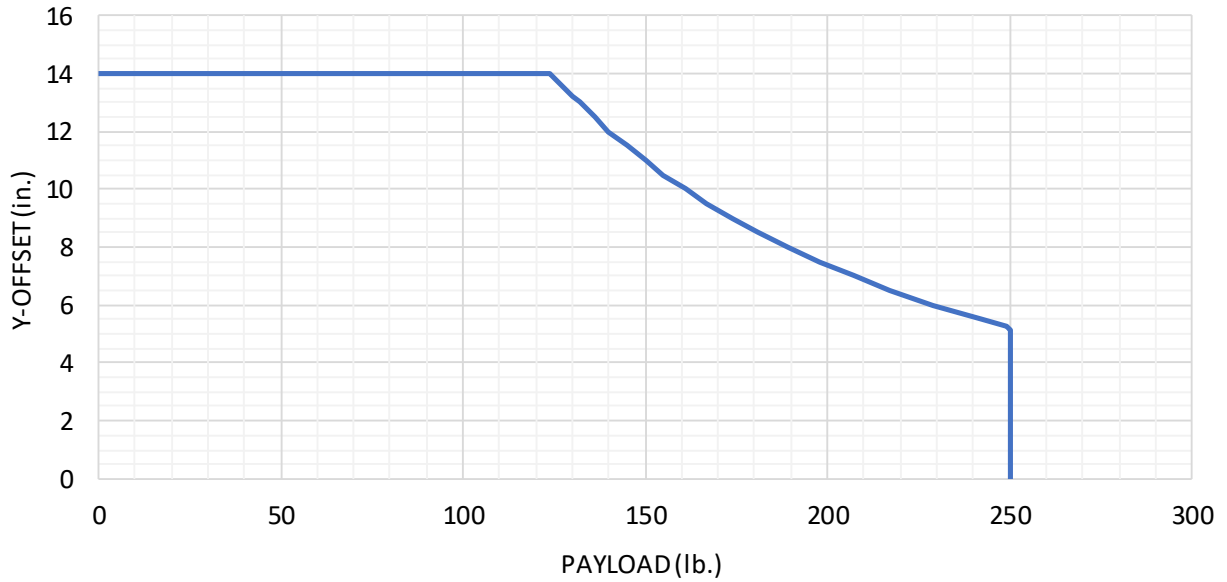

LP1 PITCH ANGLE v. PAYLOAD CAPACITY

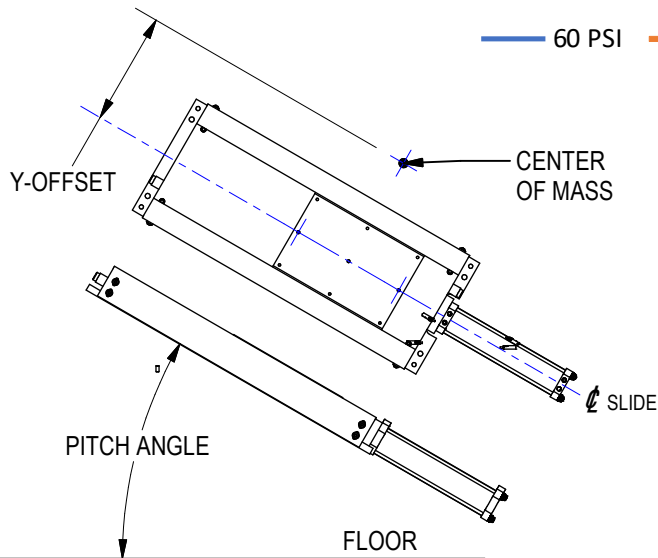
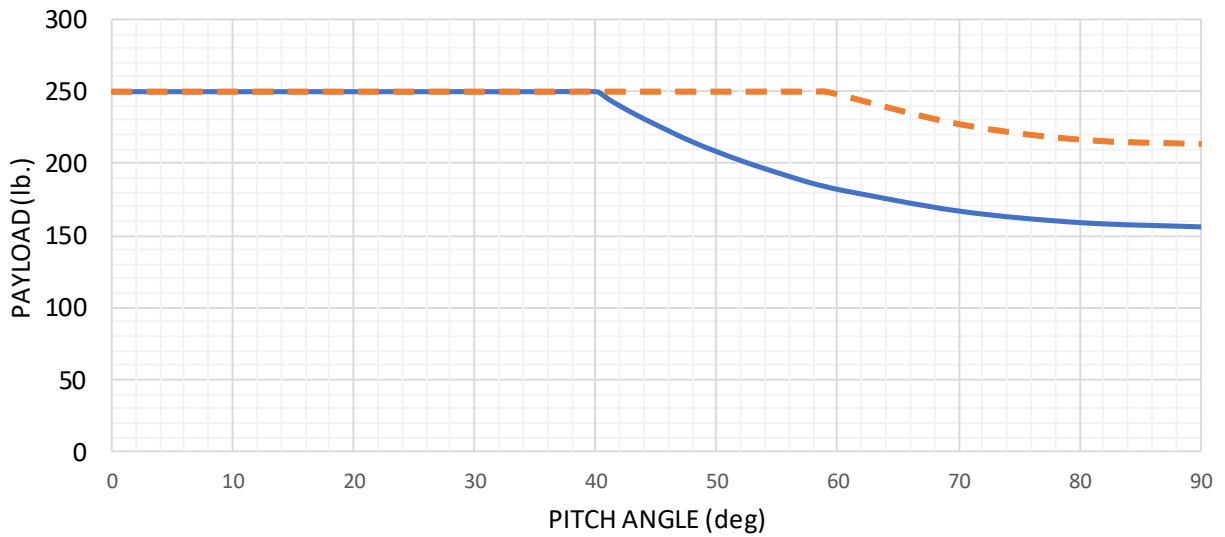

When using these graphs, applications are evaluated on two separate criteria: payload v. offset and pitch angle v. payload. An approved application meets both criteria. For applications outside the graph safety zone, contact Welker.

ALL DIMENSIONS ARE MILLIMETERS
UNLESS OTHERWISE NOTED
DO NOT SCALE DRAWING

WELKER
ENGINEERED PRODUCTS
800-229-0890 welkerproducts.com

LP2 SLIDE ACCURACY

POSITIONAL ACCURACY specifies the allowable deviation between the nominal position of a reference point on the carriage (D1 as shown) to the actual position that is achieved.

TRAVEL ACCURACY specifies the allowable deviation along the plane of motion of a reference point on the carriage (D1 as shown) to the actual position *during movement* - in other words, the allowable side-to-side movement (in the direction of Y) and up-and-down movement (in the direction of Z) as the unit travels.

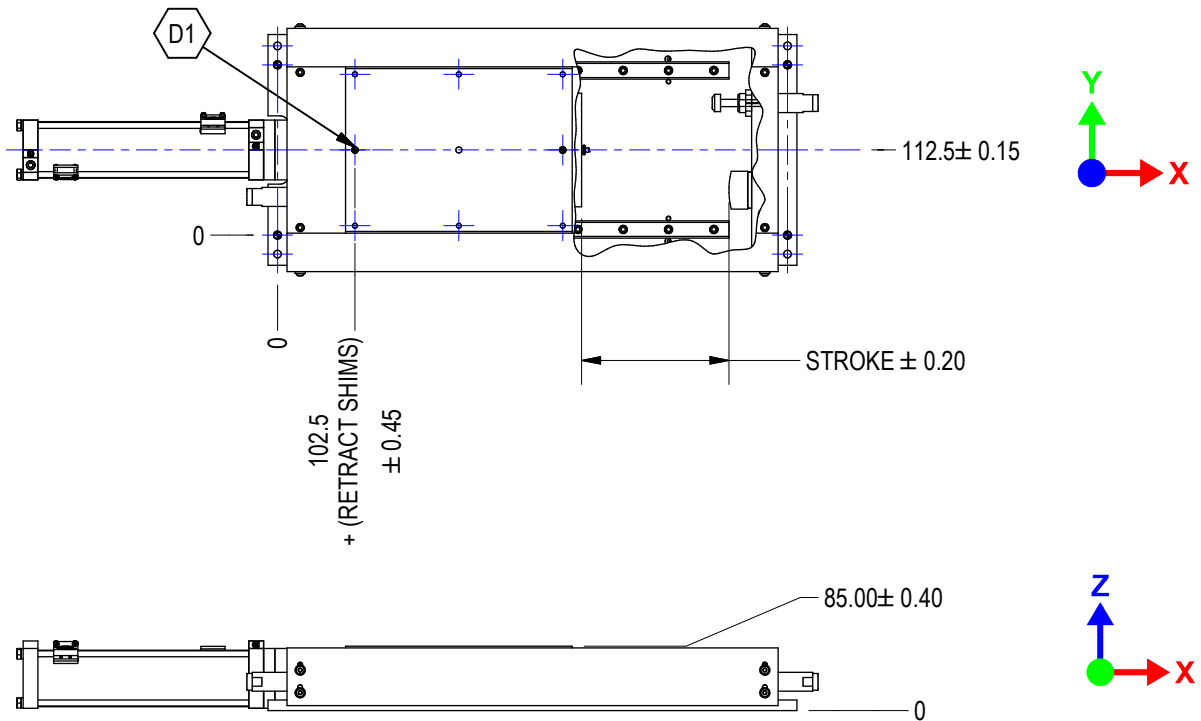

TRAVEL ACCURACY (RUNOUT)	
Y-DIRECTION	Z-DIRECTION
0.15	0.15

ALL DIMENSIONS ARE MILLIMETERS
UNLESS OTHERWISE NOTED
DO NOT SCALE DRAWING

ENGINEERED PRODUCTS
800-229-0890 welkerproducts.com

LP2 PAYLOAD v. Y-OFFSET CAPACITY

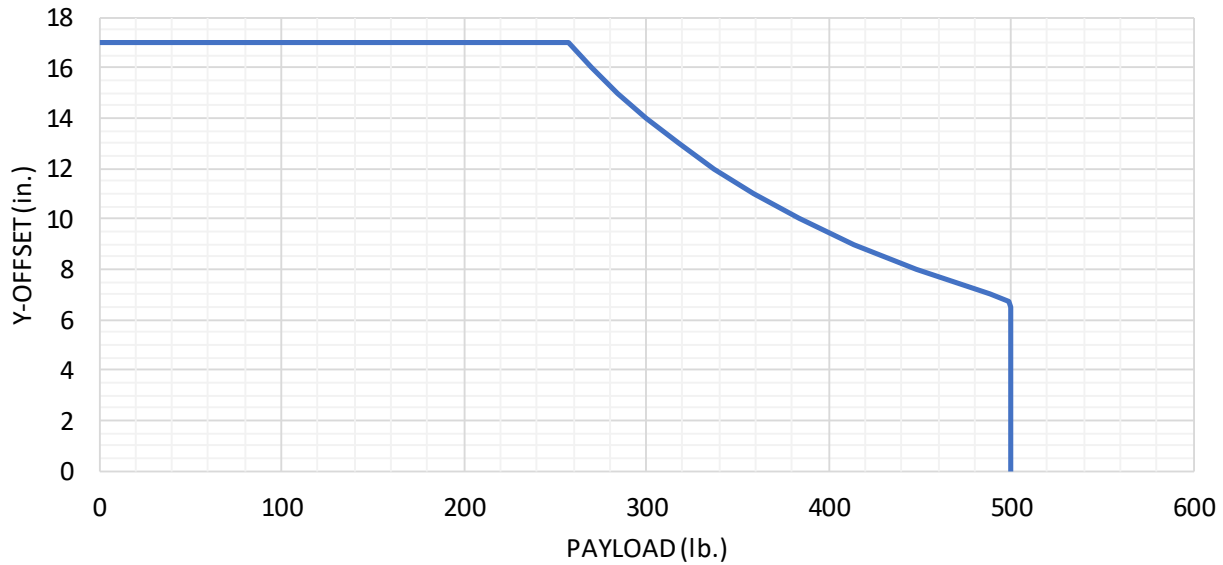

LP2 PITCH ANGLE v. PAYLOAD CAPACITY

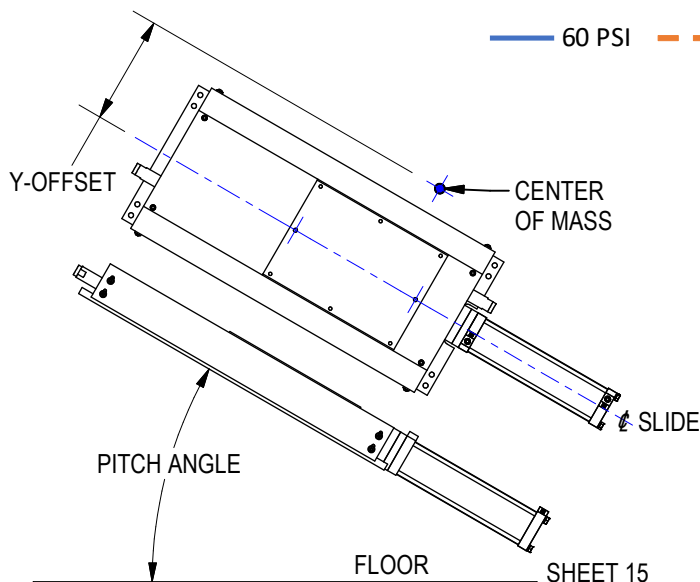
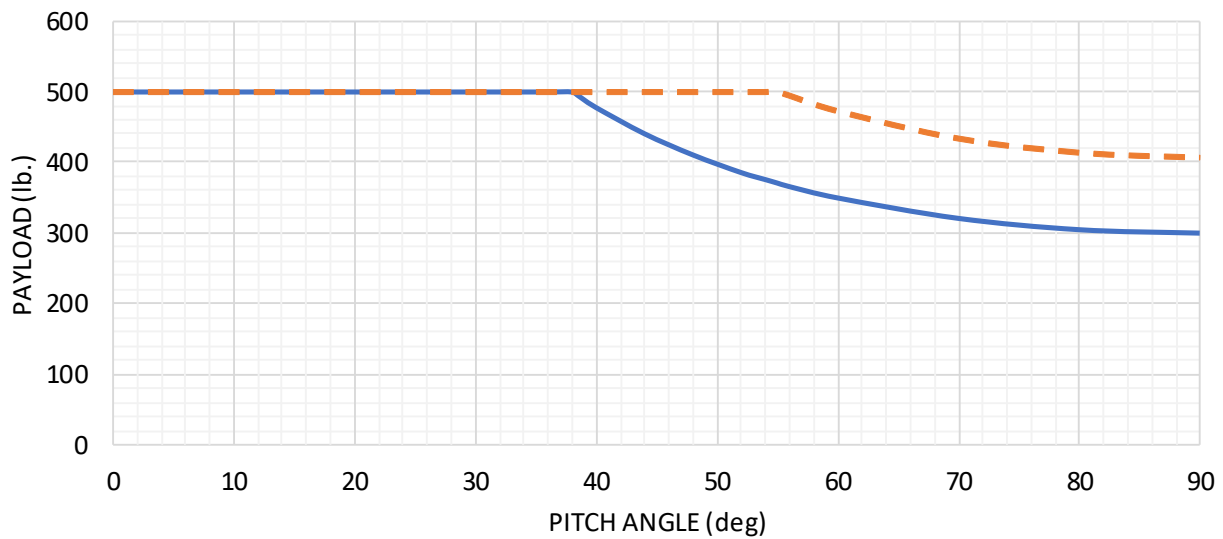

When using these graphs, applications are evaluated on two separate criteria: payload v. offset and pitch angle v. payload. An approved application meets both criteria. For applications outside the graph safety zone, contact Welker.

ALL DIMENSIONS ARE MILLIMETERS
UNLESS OTHERWISE NOTED
DO NOT SCALE DRAWING

WELKER
ENGINEERED PRODUCTS
800-229-0890 welkerproducts.com