

DB SERIES GUIDED SLIDE MAINTENANCE MANUAL

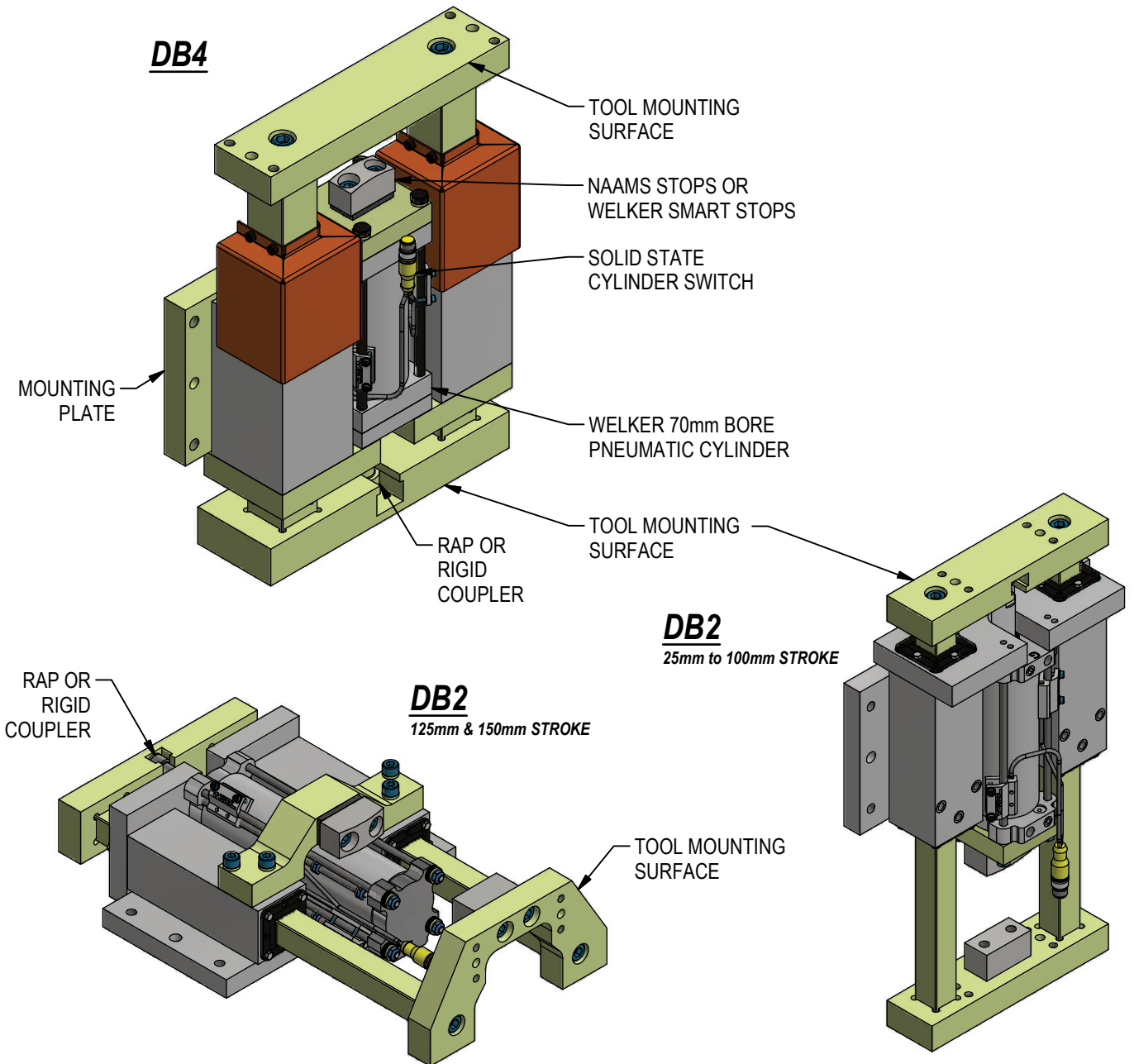

MAINTENANCE

SAFETY FIRST! MAINTENANCE SHOULD ONLY BE PERFORMED BY QUALIFIED PERSONNEL. PROPER SAFETY GEAR AND PROCEDURES MUST BE USED AT ALL TIMES. BEFORE PERFORMING MAINTENANCE, CUT OFF AIR SUPPLY TO THE UNIT, ENSURE THAT ALL AIR IS REMOVED AND THAT THERE ARE NO "TRAPPED AIR" CONDITIONS.

PREVENTATIVE MAINTENANCE: Regularly inspect unit to verify proper operation. Check for debris build up and clean as needed. Inspect all pneumatic, electrical, and mounting connections, making sure all connections are tight and secure.

CYLINDER: Welker pneumatic cylinders are lube free and require very little maintenance. Check for abnormal wear or damage. Plant air supply to the cylinder should be free of contaminants, filtered to a minimum of 50micron and have a water separator. Be sure fittings are in good condition. Seals are subject to wear under normal operating conditions. It is recommended to keep a spare cylinder seal kit on hand.

SWITCH: Switches may fail and need replacement; it is recommended to keep a spare switch on hand.

WIPER: Welker recommends annual changing of urethane wiper. Wipers are maintenance items and are not covered under standard product warranty.

WELKER RECOMMENDS IN-PLANT RECERTIFICATION AFTER SERVICE/REPAIR/REPLACEMENT.

TROUBLESHOOTING

FAILURE	POSSIBLE CAUSE	SOLUTION
Unit does not extend/retract.	Cylinder failure Switch failure	Inspect unit for dirt/debris. Check plant air supply for proper pressure; too little will result in lack of cylinder movement. Seals may be worn, damaged or deteriorating. Replace as needed. If cylinder has been serviced, be sure tie rod nuts have been tightened to torque specifications. Check switch for proper operation. Replace as needed.
Unit stutters on extend or retract.	Unbalanced load	Confirm load vs working envelope. For some offset loads, a counterbalance may be needed to balance load. All loads must be within working envelope. Consult Welker Engineering for assistance.

REPLACEMENT PARTS

* RECOMMENDED SPARE PARTS TO KEEP IN STOCK

QTY	STOCK*	DESCRIPTION	PART NUMBER
4	4	DB4 WIPER	WIPER-40-KIT
1		DB4 PNEUMATIC CYLINDER ~ NPT PORTS	DB4-RCA-STROKE-01
1		DB4 PNEUMATIC CYLINDER ~ G PORTS	DB4-RCA-STROKE-02
	1	DB4 PNEUMATIC CYLINDER SEAL KIT	DB4-CSK
4	4	DB2 WIPER	WIPER-24
	1	DB2 PNEUMATIC CYLINDER SEAL KIT	DB2-CSK
1	1	CYLINDER SWITCH	SEE CHART BELOW
2	1	WELKER SMART STOP	ASC020-PD

	Reorder #	Mfr. Part Number	Manufacturer	Description
Cylinder Switches	SWITCH L3	SWITCH L3 L3 switch is weld field immune*, comparable to World Switches	Welker	4-Wire, 4-Pin, DC M12 X 1 (PNP) Quick Disconnect
	SWITCH L5	MK5113	ifm Eector	3-Wire, 4-Pin, DC M12 X 1 (NPN) Quick Disconnect

Standard Switch Option - All other options may affect price and delivery

*Note that some mid and low frequency DC resistance applications (i.e. aluminum resistance welding applications) may cause a fault. In these applications, it is recommended that the sensor be ignored/bypassed during the welding cycle.

RAM WIPER MAINTENANCE

Welker recommends annual changing of urethane wiper. Wipers are maintenance items and are not covered under standard product warranty. Steam cleaning or wiping contamination off during the course of normal machine maintenance is desirable.

NOTE: WIPERS ARE LOCATED ON BOTH ENDS OF UNIT RAM, 4 TOTAL

1. Disengage plant air from unit. Isolate unit from tooling.
2. Remove screws & lock washers from tie plate. Remove tie plate.
3. DB4 - For wiper on shroud end: Remove shroud screws. Remove shroud. Remove wiper screws. Remove wiper retainer. Remove wiper.
4. DB2 - Remove wiper screws. Remove wiper.
5. Clean ram, removing residual debris.
6. Install new wiper using a small amount of Magnalube G grease applied to inside of wiper.
7. Install new wiper retainer (DB4 only)
8. Secure with wiper screws.
9. Install shroud with shroud screws. (DB4 only)
10. Install tie plate to torque shown. Install unit to tooling.
11. Engage plant air, making sure lines are free of contaminants.

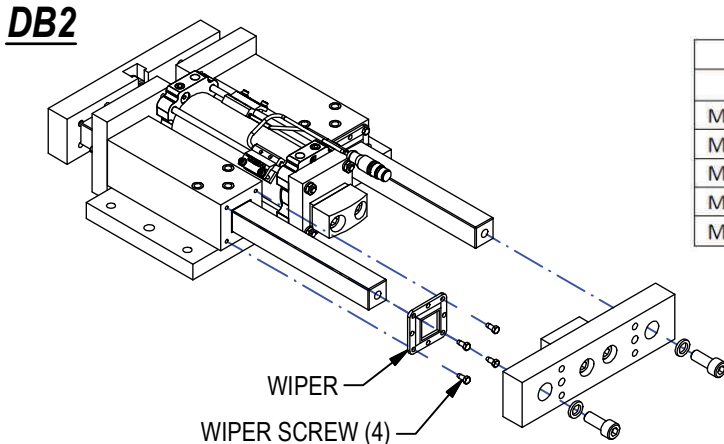
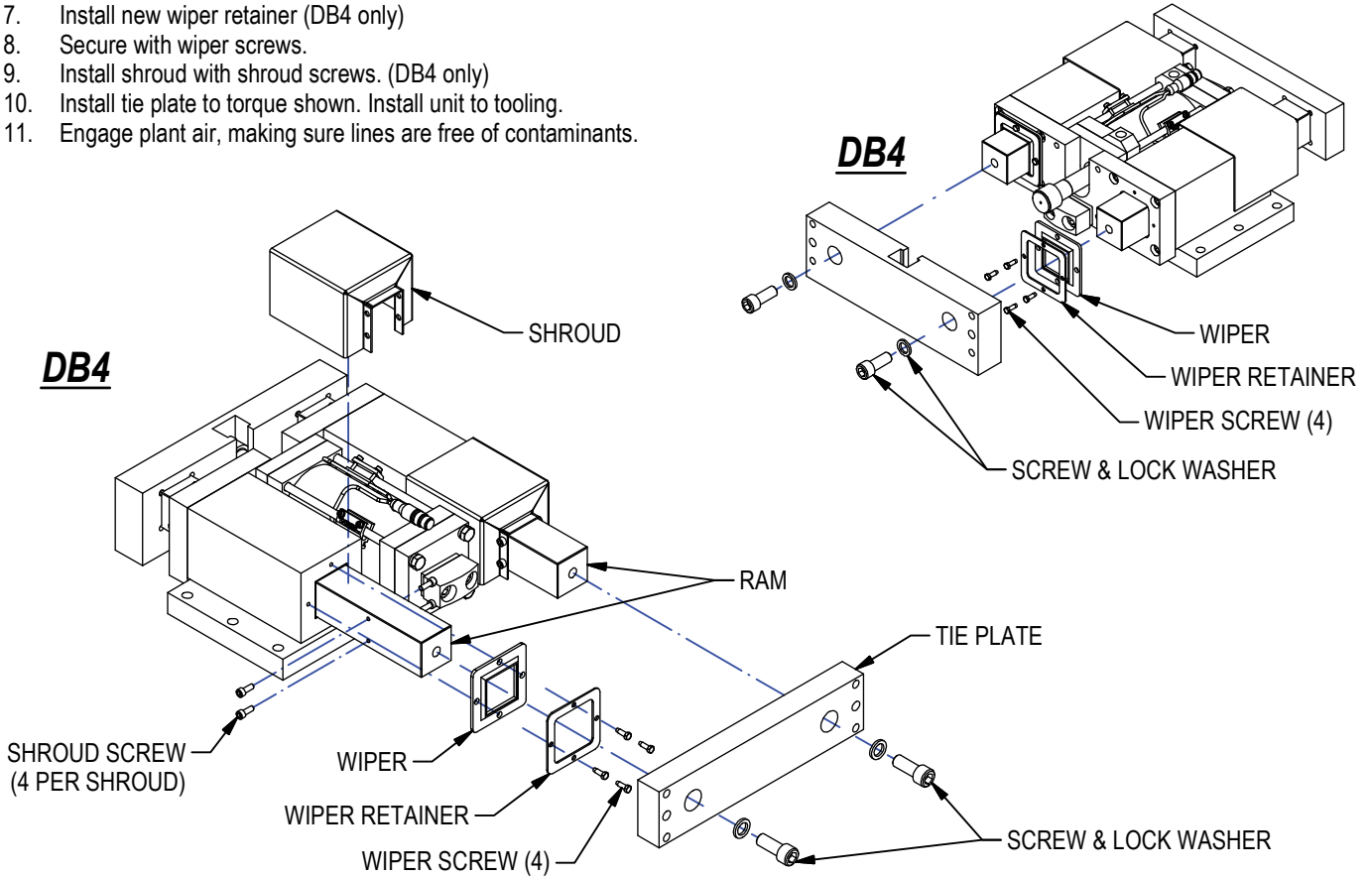

	Tightening Torques for Metric Bolts (installed dry)			
	Steel		Aluminum	
M5	10 Nm	7.375 ft lb.	5 Nm	3.6875 ft lb.
M6	19 Nm	14.014 ft lb.	9.5 Nm	7.007 ft lb.
M8	45 Nm	33.19 ft lb.	22.5 Nm	16.595 ft lb.
M10	89 Nm	65.643 ft lb.	44.5 Nm	32.8215 ft lb.
M12	156 Nm	115.06 ft lb.	78 Nm	57.53 ft lb.

DB4 CYLINDER / SEAL MAINTENANCE

TO REMOVE CYLINDER:

1. Disconnect air lines from unit. If applicable: disconnect Smart Stop; disconnect and remove cylinder switch, noting positions on tie rods.
2. Loosen cylinder tie rods enough to dislodge cylinder from tie plate. **KEEP CYLINDER ASSEMBLED**
3. Lift cylinder away from unit, sliding coupler out of slot. Note placement of rigid adapter if present.

TO REPLACE CYLINDER SEALS:

Cylinder seal kit includes: rod wiper, adapter inner & outer seals, piston seal, and 2 tube seals.

1. Remove coupler from cylinder rod (coupler is affixed using removable adhesive).
2. Remove adapter. Replace rod wiper, inner and outer adapter seals.
3. Remove end cap and cylinder tube noting port position of end caps. Clean seal grooves thoroughly. Replace tube seals.
4. Remove piston seal using plastic or brass tool. **NOTE ORIENTATION OF SEAL.** Inspect parts for wear. Clean piston and install new seal.
5. Lightly coat the piston seal and tube I.D. with Magnalube G grease.
6. Reassemble cylinder. Make sure tube seals are seated properly in grooves and are not being pinched.
7. Install coupler to cylinder rod using permanent thread adhesive.
8. Return cylinder to unit.
9. Secure tie rods evenly to tie plate. Tighten in an "X" pattern to torque specifications.
10. Check for leaks.
11. Reconnect any necessary switches.

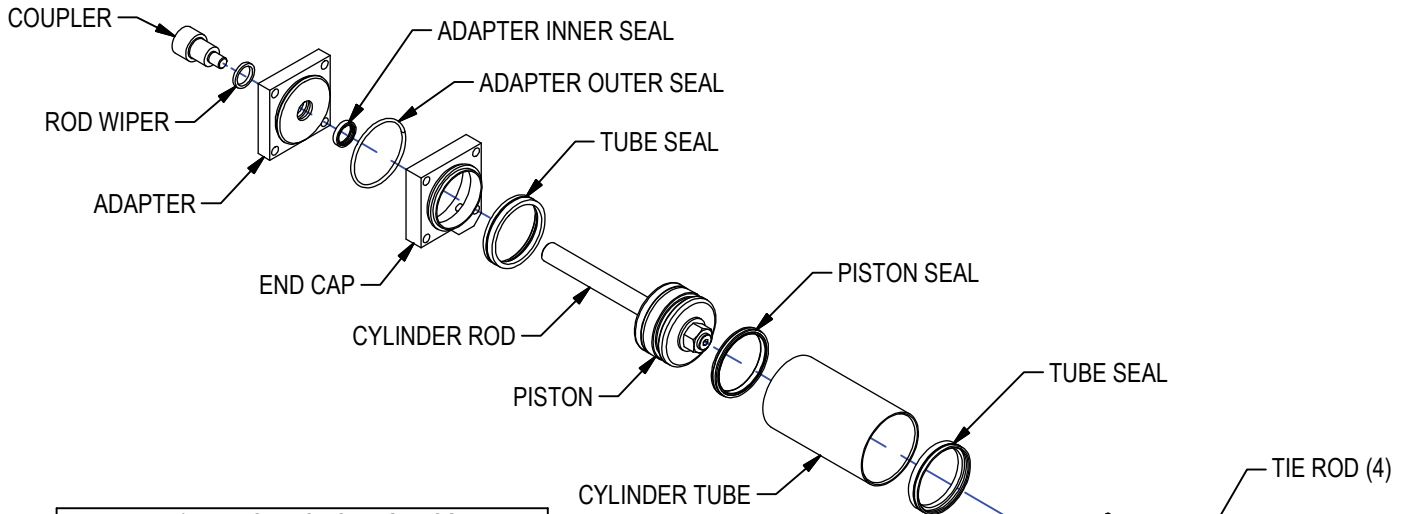
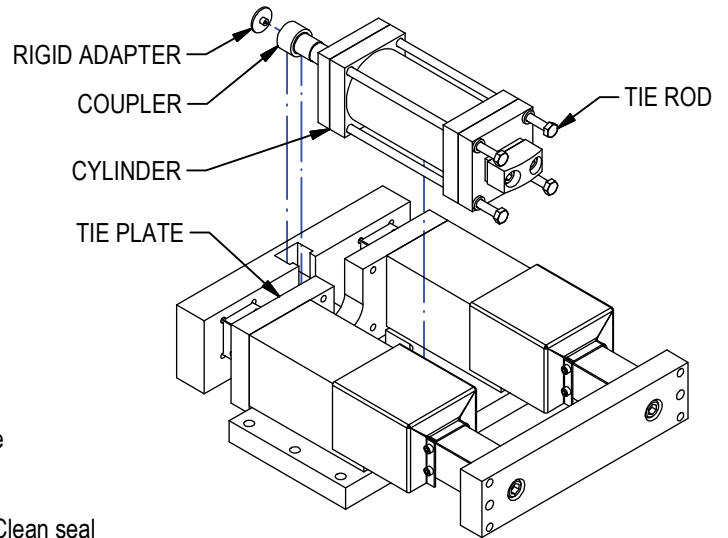

DB4 TIE ROD TORQUE SPECS			
THREAD	FT-LBF	IN-IBF	N-M
5/16-24"	12	144	16.3

Tightening Torques for Metric Bolts (installed dry)				
	Steel		Aluminum	
M5	10 Nm	7.375 ft lb.	5 Nm	3.6875 ft lb.
M6	19 Nm	14.014 ft lb.	9.5 Nm	7.007 ft lb.
M8	45 Nm	33.19 ft lb.	22.5 Nm	16.595 ft lb.
M10	89 Nm	65.643 ft lb.	44.5 Nm	32.8215 ft lb.
M12	156 Nm	115.06 ft lb.	78 Nm	57.53 ft lb.

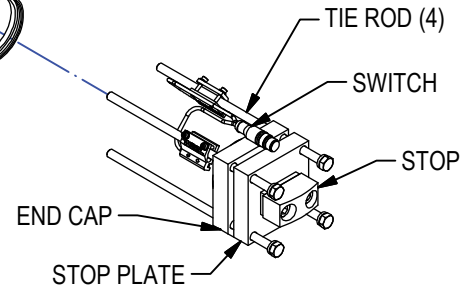
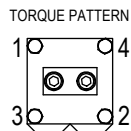

DB2 CYLINDER / SEAL MAINTENANCE

TO REMOVE CYLINDER:

1. Disconnect air lines from unit. If applicable: disconnect Smart Stop; disconnect and remove cylinder switch, noting positions on tie rods.
2. Loosen tie rods securing cylinder to tie plate.
3. Lift cylinder away from unit, sliding coupler out of slot. Note placement of rigid adapter if present.

NOTE: USE CARE WHEN HANDLING - KEEP CYLINDER TOGETHER! TIE RODS HOLD CYLINDER TOGETHER AS WELL AS SECURING TO TIE PLATE. WHEN TIE RODS ARE LOOSE, CYLINDER MAY COME APART.

TO REPLACE CYLINDER SEALS:

Cylinder seal kit includes: rod wiper & seal, Igus bearing, piston inner & outer seals, and 2 tube seals.

1. Remove tie rods, nuts & lock washers (4) from cylinder assembly. Remove stop block. Remove rear end cap, cylinder tube and tube seals. Note orientation of end cap ports.
2. Remove hex jam nut and washer from cylinder rod (hex jam nut is affixed using removable adhesive).
3. Remove piston. Remove piston outer seal using plastic or brass tool. NOTE ORIENTATION OF SEAL. Inspect parts for wear. Clean piston. Lightly coat the piston outer seal with Acrolube grease and install to piston.
4. Replace piston inner seal.
5. Remove cylinder rod/coupler from front end cap. Remove rod wiper, Igus bearing and rod seal. Note orientation of wiper & seal. Clean seal grooves thoroughly.
6. Lightly coat the wiper, seals and tube I.D. with Magnalube G grease.
7. Install new rod wiper, Igus bearing, rod seal to end cap. Install cylinder rod to piston with hex jam nut and washer using removable thread adhesive.
8. Lightly coat tube seals with Acrolube grease. Reassemble cylinder. Make sure tube seals are seated properly in grooves and are not being pinched. Tighten cylinder tie rod nuts to torque shown.
9. Return cylinder to unit. Reassemble stop block to cylinder. Secure tie rods evenly to tie plate.
10. Tighten to torque shown.
11. Check for leaks. Reconnect any necessary switches.

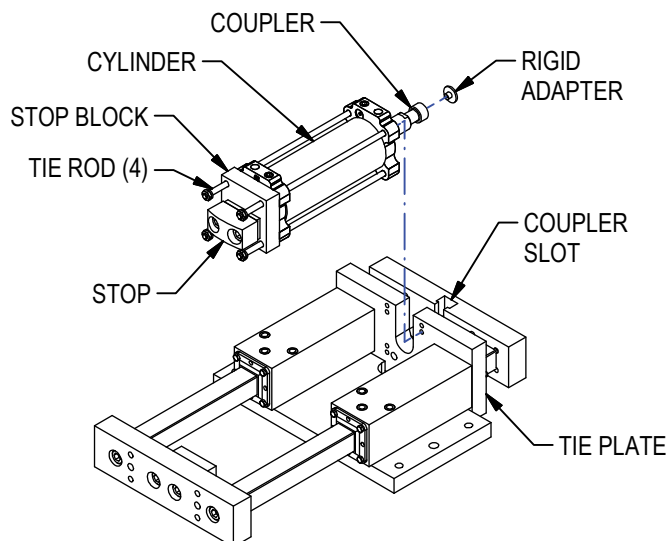

NOTE: 125 & 150 STROKE UNITS DO NOT HAVE A STOP BLOCK. STOP IS MOUNTED TO TOP TIE PLATE.

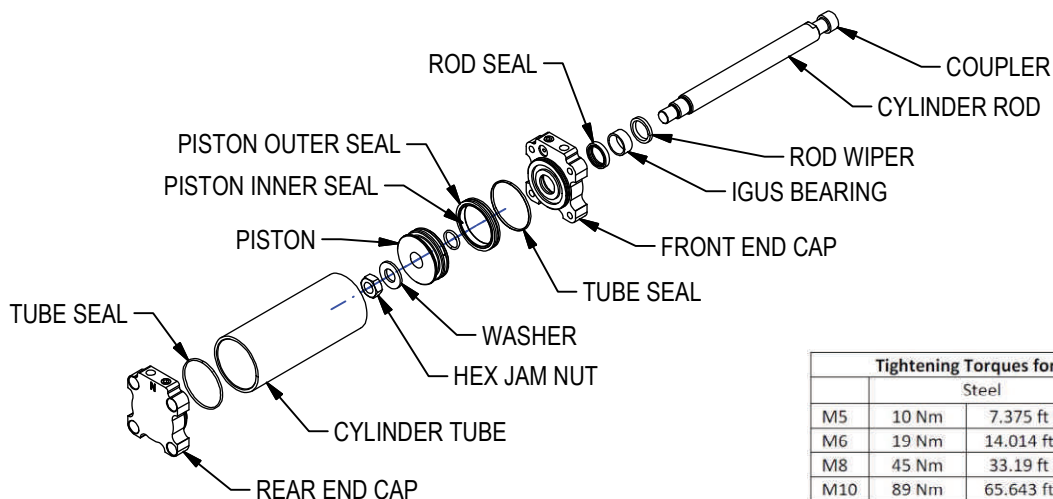
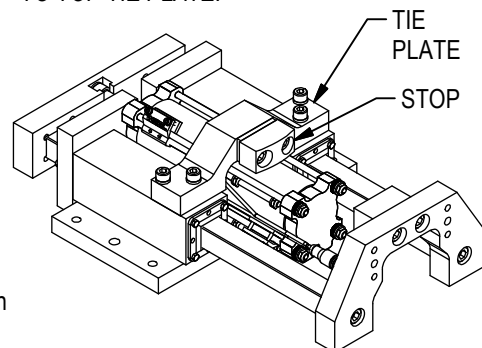

	Tightening Torques for Metric Bolts (installed dry)			
	Steel		Aluminum	
M5	10 Nm	7.375 ft lb.	5 Nm	3.6875 ft lb.
M6	19 Nm	14.014 ft lb.	9.5 Nm	7.007 ft lb.
M8	45 Nm	33.19 ft lb.	22.5 Nm	16.595 ft lb.
M10	89 Nm	65.643 ft lb.	44.5 Nm	32.8215 ft lb.
M12	156 Nm	115.06 ft lb.	78 Nm	57.53 ft lb.

REPLACING TIE ROD CYLINDER SWITCH

1. BEFORE REMOVING OLD SWITCH: NOTE SENSOR PLACEMENT!
FOR SWITCHES WITH TWO SENSORS, EACH WILL BE TAGGED
WITH A BAND AROUND THE WIRE INDICATING S1 AND S2 (OR S01
AND S02).
2. TO REMOVE SWITCH, REMOVE BOLTS AND WASHERS FROM
BRACKET. SLIDE BRACKET OUT FROM TIE ROD.
3. SENSOR IS SNAPPED INTO BRACKET. REMOVE.
4. INSTALL NEW SWITCH SENSOR FLUSH INTO BRACKET, BEING
CAREFUL TO MATCH SENSOR CORRECTLY TO LOCATION ON
CYLINDER.
5. LOCATE BRACKET TO CYLINDER, SLIDE ON TO TIE ROD. SECURE
WITH BOLTS & WASHERS.

