

ORDERING NUMBER:
 #CLM40-STROKE-{CYLINDER}

SEE CHART BELOW
 STROKE IS 25mm-1,000mm

ORDERING EXAMPLES:
 TO ORDER UNIT WITH WELKER 100mm BORE X 150mm STROKE LOCKING CYL W/ NPT PORTS, AS SHOWN, ORDER AS:
 #CLM40-150-WEL4

NOTES:
 2X M10 SHCS @ LOCATION "C" SHOULD BE LEFT CLEAR IF SHIMMING IN THE RETRACTED POSITION IS REQ'D.
 60psi LOAD CAP. FOR STD LOCKING & NON-LOCKING AIR CYL: 365lbf (EXTEND) - 325lbf (RETRACT)

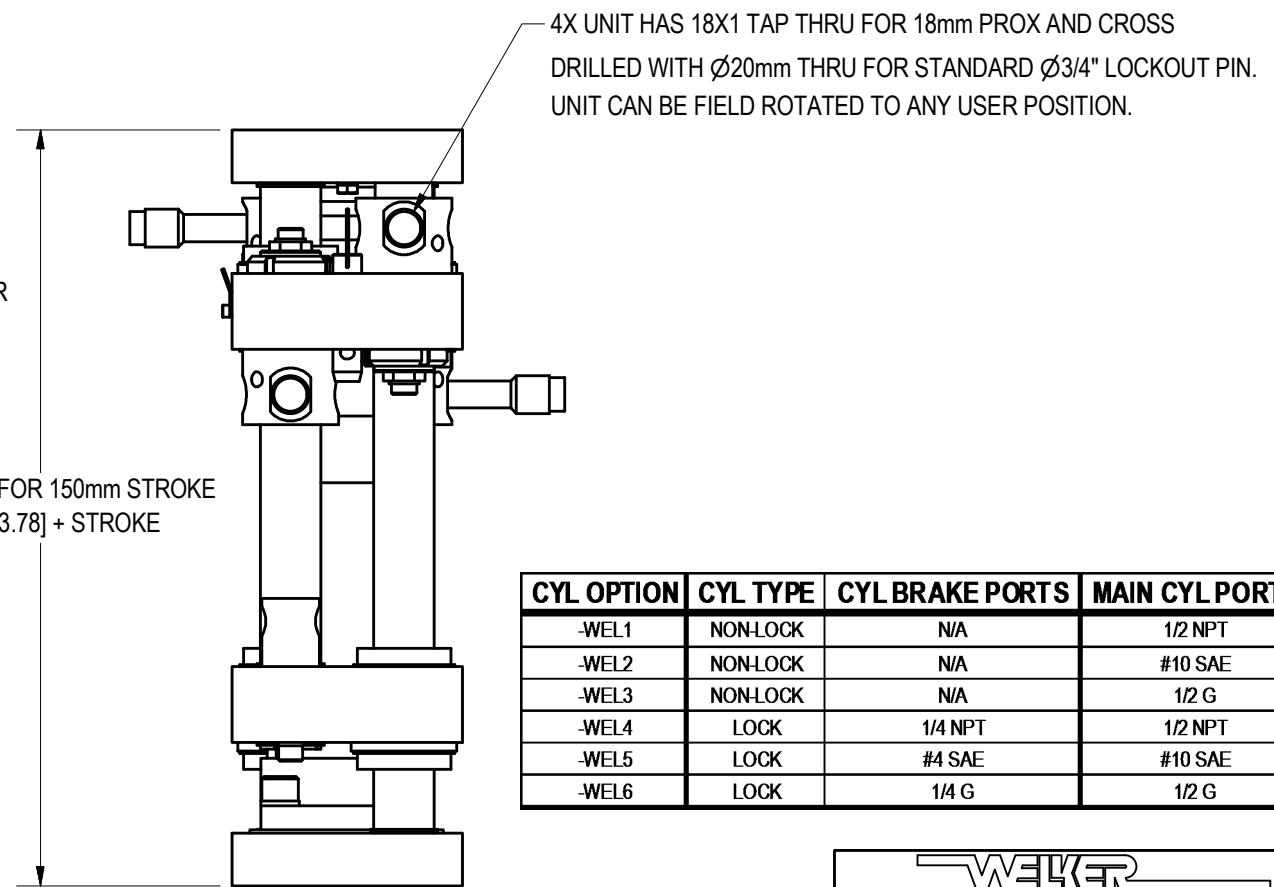
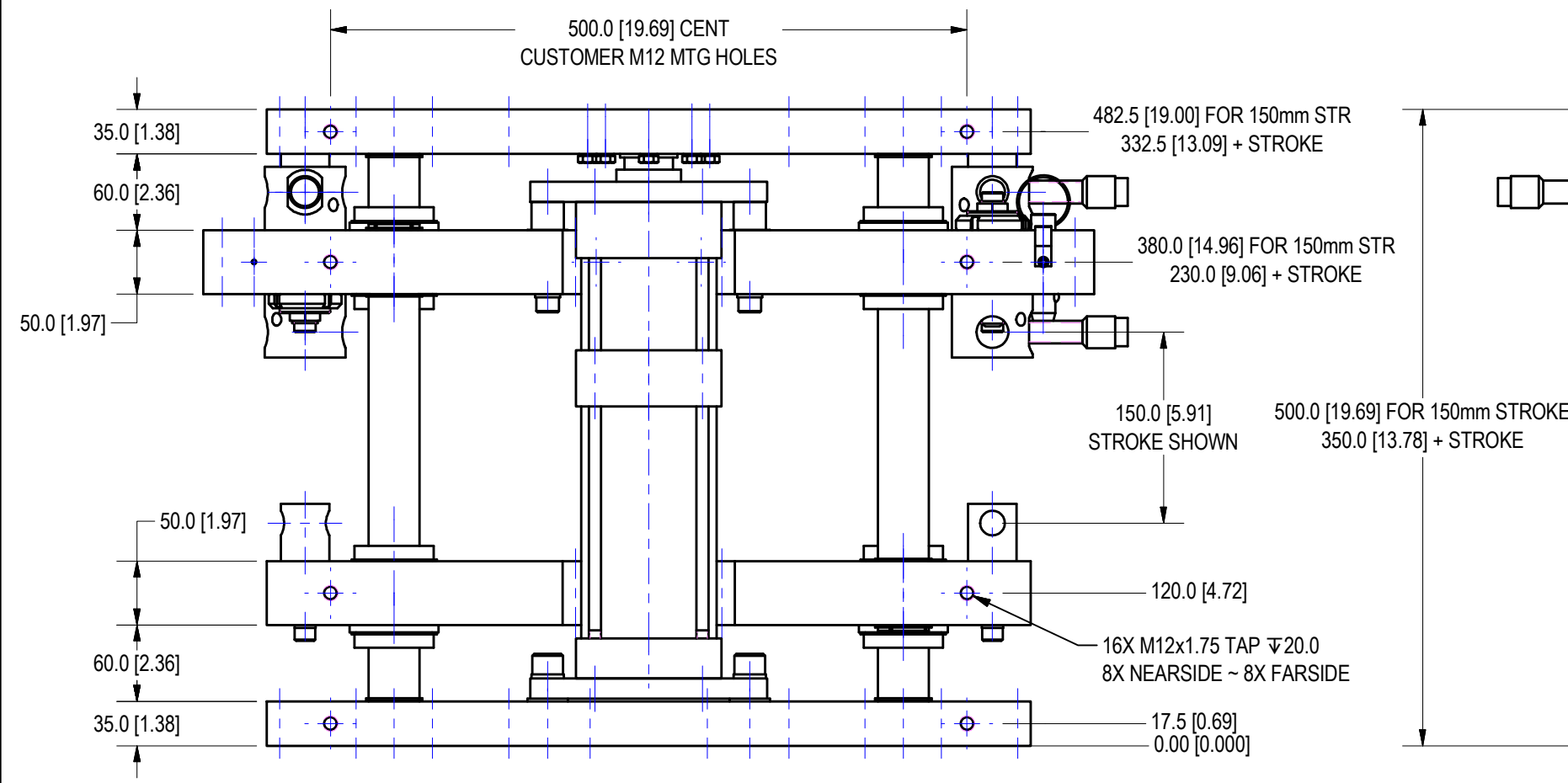

CYL OPTION	CYL TYPE	CYL BRAKE PORTS	MAIN CYL PORTS
-WEL1	NON-LOCK	N/A	1/2 NPT
-WEL2	NON-LOCK	N/A	#10 SAE
-WEL3	NON-LOCK	N/A	1/2 G
-WEL4	LOCK	1/4 NPT	1/2 NPT
-WEL5	LOCK	#4 SAE	#10 SAE
-WEL6	LOCK	1/4 G	1/2 G

UNITS ARE MILLIMETERS
 (i.e.X.XXmm [x.xxx"])
 DO NOT SCALE DRAWING

DATE	STATUS	DRAWN BY	DATE	CHK'D BY	ENG APPROVAL
12/14/2006	Released	GSK	10/11/2011	RCA	

SCALE 1:5 FILE NAME CLM40L01

WELKER
 BEARING COMPANY

TOOL NAME
 METRIC LIFTER ASSEMBLY

TEMPLATE