

ORDERING NUMBER:
#CLM40-STROKE-{CYLINDER}

SEE CHART BELOW
STROKE IS 100mm-1,000mm

ORDERING EXAMPLES:
TO ORDER UNIT WITH WELKER 100mm BORE X 150mm STROKE LOCKING CYL W/ NPT PORTS, AS SHOWN, ORDER AS:
#CLM40-150-WEL4
TO ORDER UNIT WITH WELKER 100mm BORE LOCKING CYL, G PORTS, 150mm TOTAL STROKE X 50mm INITIAL STROKE & NPT PORTS
#CLM40-150-50-WEL6

NOTES:
2X M10 SHCS @ LOCATION "C" SHOULD BE LEFT CLEAR IF SHIMMING IN THE RETRACTED POSITION IS REQ'D.
60psi LOAD CAP. FOR STD LOCKING & NON-LOCKING AIR CYL: 365lbf (EXTEND) - 325lbf (RETRACT)

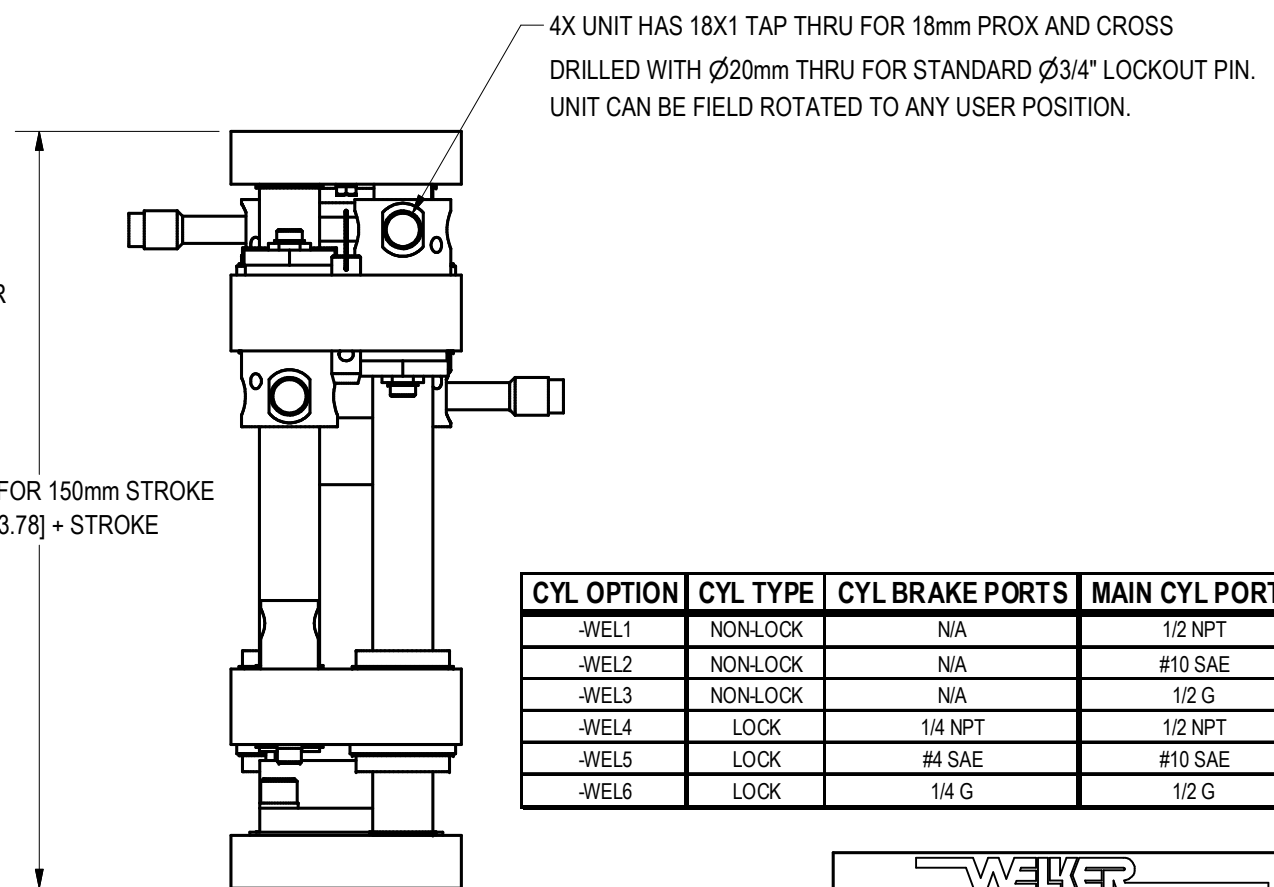
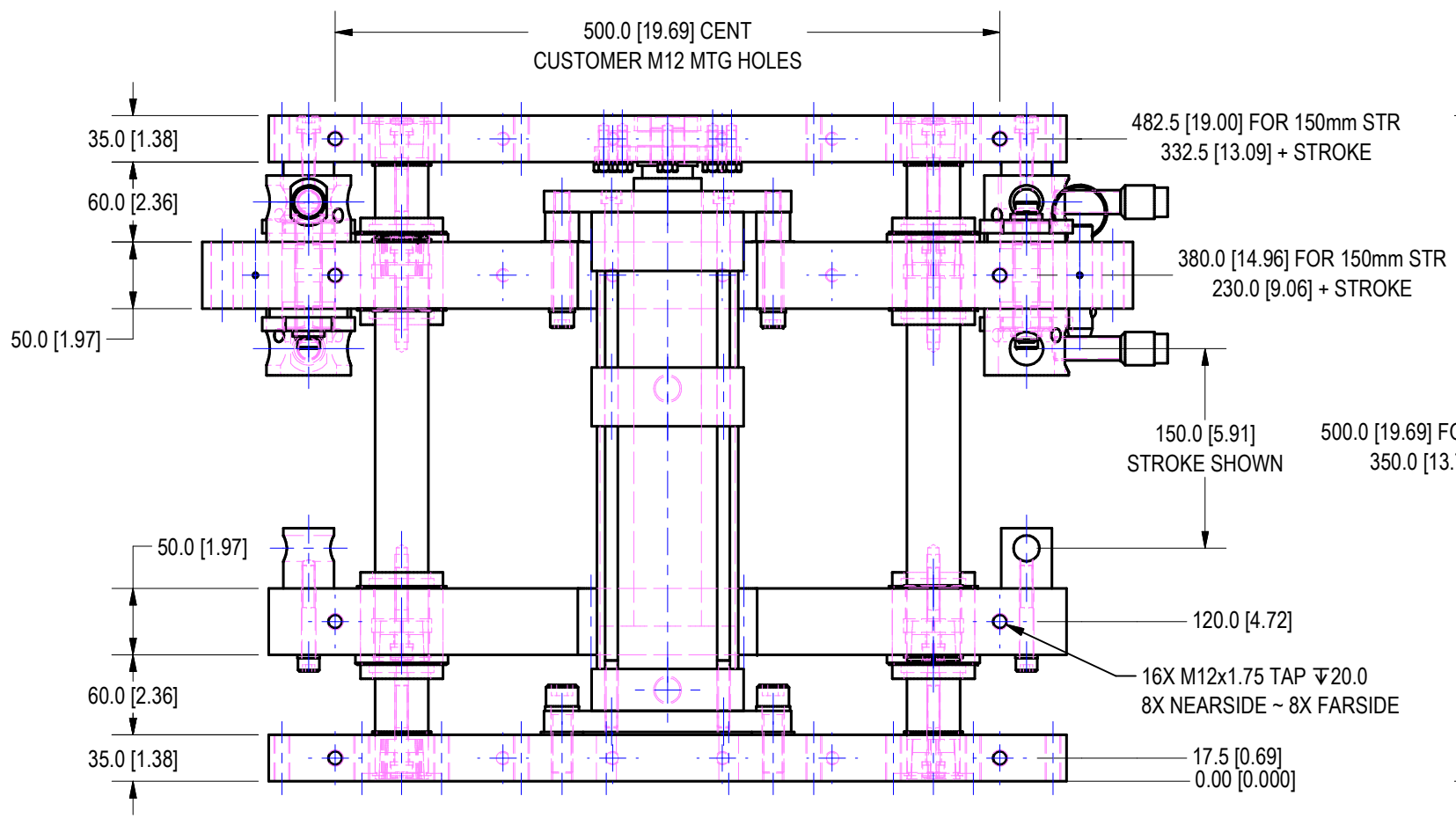

CYL OPTION	CYL TYPE	CYL BRAKE PORTS	MAIN CYL PORTS
-WEL1	NON-LOCK	N/A	1/2 NPT
-WEL2	NON-LOCK	N/A	#10 SAE
-WEL3	NON-LOCK	N/A	1/2 G
-WEL4	LOCK	1/4 NPT	1/2 NPT
-WEL5	LOCK	#4 SAE	#10 SAE
-WEL6	LOCK	1/4 G	1/2 G

UNITS ARE MILLIMETERS
(i.e.X.XXmm [x.xxx"])
DO NOT SCALE DRAWING

WELKER BEARING COMPANY					
TOOL NAME METRIC LIFTER ASSEMBLY					
TEMPLATE					
DATE	STATUS	DRAWN BY	DATE	CHK'D BY	ENG APPROVAL
12/14/2006	Released	GSK	1/4/2007	RCA	
SCALE		1:5		FILE NAME	CLM40L01