

MAINTENANCE MANUAL LOCKOUT PINS: BP1, BP2, BP4

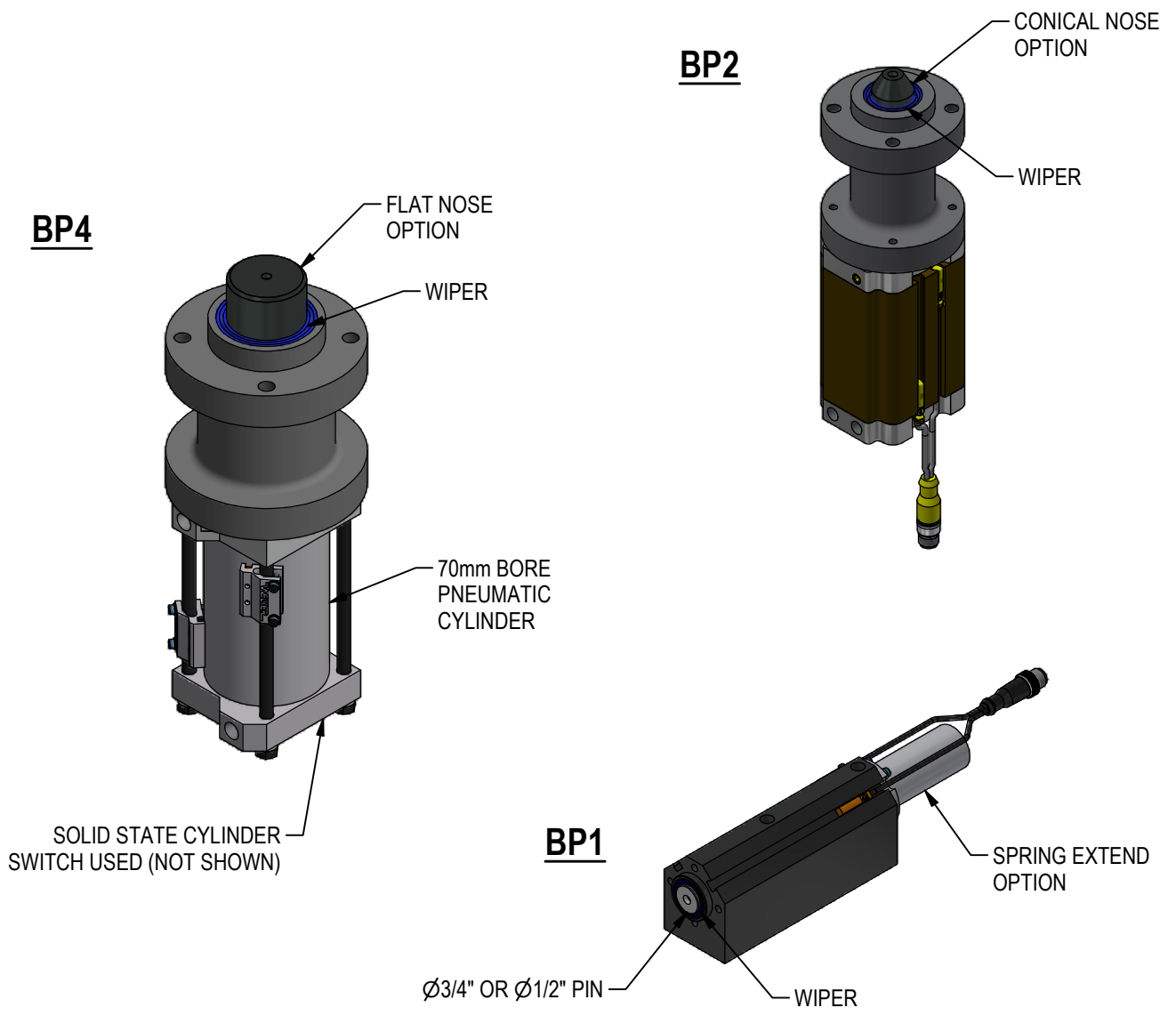

MAINTENANCE

SAFETY FIRST!

MAINTENANCE SHOULD ONLY BE PERFORMED BY QUALIFIED PERSONNEL. PROPER SAFETY GEAR AND PROCEDURES MUST BE USED AT ALL TIMES.

BEFORE PERFORMING MAINTENANCE, CUT OFF AIR SUPPLY TO THE UNIT, ENSURE THAT ALL AIR IS REMOVED AND THAT THERE ARE NO "TRAPPED AIR" CONDITIONS.

PREVENTATIVE MAINTENANCE: Regularly inspect unit to verify proper operation. Check for debris build up and clean as needed. Inspect all pneumatic, electrical, and mounting connections, making sure all connections are tight and secure. Routine replacement of cylinder seals is recommended.

CYLINDER: Welker pneumatic cylinders are lube free and require very little maintenance. Check for abnormal wear or damage. Plant air supply to the cylinder should be free of contaminants, filtered to a minimum of 50micron and have a water separator. Be sure fittings are in good condition.

PINS: Under normal operating conditions pins should require no maintenance.

WIPERS: Replace when damaged or worn.

SWITCH: Switches may fail and need replacement; it is recommended to keep a spare switch on hand.

TROUBLESHOOTING

FAILURE	POSSIBLE CAUSE	SOLUTION
Pin does not extend or fully extend.	Cylinder failure Switch failure	Inspect unit for dirt/debris. Check plant air supply for proper pressure; too little will result in lack of cylinder movement and too much can result in cylinder seal failure. If cylinder has been serviced, be sure cylinder bolts have been tightened to torque specifications. Check switch for proper operation. Replace as needed.
Pin does not fully extend.	Spring failure	Replace spring
Switch sensor failing	Switch failure Incorrect switch sensor position	Check switch for proper operation. Replace as needed. Validate sensor position in relation to cylinder magnet.

REPLACEMENT PARTS

When ordering replacement parts, please have the unit's Welker Job Number available.

BP1 REPLACEMENT PARTS			
QTY	STOCK*	DESCRIPTION	PART NUMBER
1	1	BP1 WIPER - 3/4" PIN STYLE A (INCLUDED IN BP1-CSK)	MC0750X1000-125N
1		BP1 PIN - 3/4" PIN STYLE A	BP1E02A
1	1	BP1 WIPER - 1/2" PIN STYLE B (INCLUDED IN BP1-CSK)	MC0500X0750-125N
1		BP1 PIN - 1/2" PIN STYLE B	BP1E02B
1	1	BP1 CYLINDER SEAL KIT	BP1-CSK
	1	BP1 SPRING	S-1174
BP2 REPLACEMENT PARTS			
QTY	STOCK*	DESCRIPTION	PART NUMBER
1		BP2 WIPER (INCLUDED IN BP2N-CSK)	MMCU-025X035X0500
	1	BP2 CYLINDER SEAL KIT	BP2N-CSK
		BP2 SPRING	SC081213-96 (BUILD DATE PRIOR TO 4/21)
		BP2 SPRING	SC09120-55 (BUILD DATE 4/21 AND LATER)
BP4 REPLACEMENT PARTS			
QTY	STOCK*	DESCRIPTION	PART NUMBER
1		BP4 WIPER (INCLUDED IN BP4N-CSK)	MC1875X2375-312U
	1	BP4 CYLINDER SEAL KIT	BP4N-CSK
1	1	BP4 GAS SPRING	R15-63.5-BK-90 BAR
SWITCH REPLACEMENT PARTS			
QTY	STOCK*	DESCRIPTION	PART NUMBER
1	1	SOLID STATE CYLINDER SWITCH	SEE CHART BELOW

* RECOMMENDED SPARE PARTS TO KEEP IN STOCK

	Reorder #	Mfr. Part Number	Manufacturer	Description
Cylinder Switches	SWITCH L3	SWITCH L3 L3 switch is weld field immune*, comparable to World Switches	Welker	4-Wire, 4-Pin, DC M12 X 1 (PNP) Quick Disconnect
	SWITCH L5	MK5113	ifm Efector	3-Wire, 4-Pin, DC M12 X 1 (NPN) Quick Disconnect

Standard Switch Option - All other options may affect price and delivery

*Note that some mid and low frequency DC resistance applications (i.e. aluminum resistance welding applications) may cause a fault. In these applications, it is recommended that the sensor be ignored/bypassed during the welding cycle.

TO REPLACE WIPER: BP2 & BP4

1. Remove air lines from the cylinder. Remove lockout unit from mount. Remove cylinder switch if applicable, noting location.
2. Loosen (4) cylinder bolts enough to free unit body. Remove unit body.
3. Remove existing wiper, being careful to note orientation of groove.
4. Install new wiper in unit body, groove placement same as old wiper. Use a flat surface/plate to install wiper; a hand press is recommended.
5. Reassemble unit body and cylinder. Using torque wrench tighten bolts to pattern shown.
BP4: tighten bolts to 15 ft.lb. BP2: tighten bolts to 14 ft.lb. Install cylinder switch if applicable.
6. Install unit to mount. Install air lines, making sure they are free of contaminants.

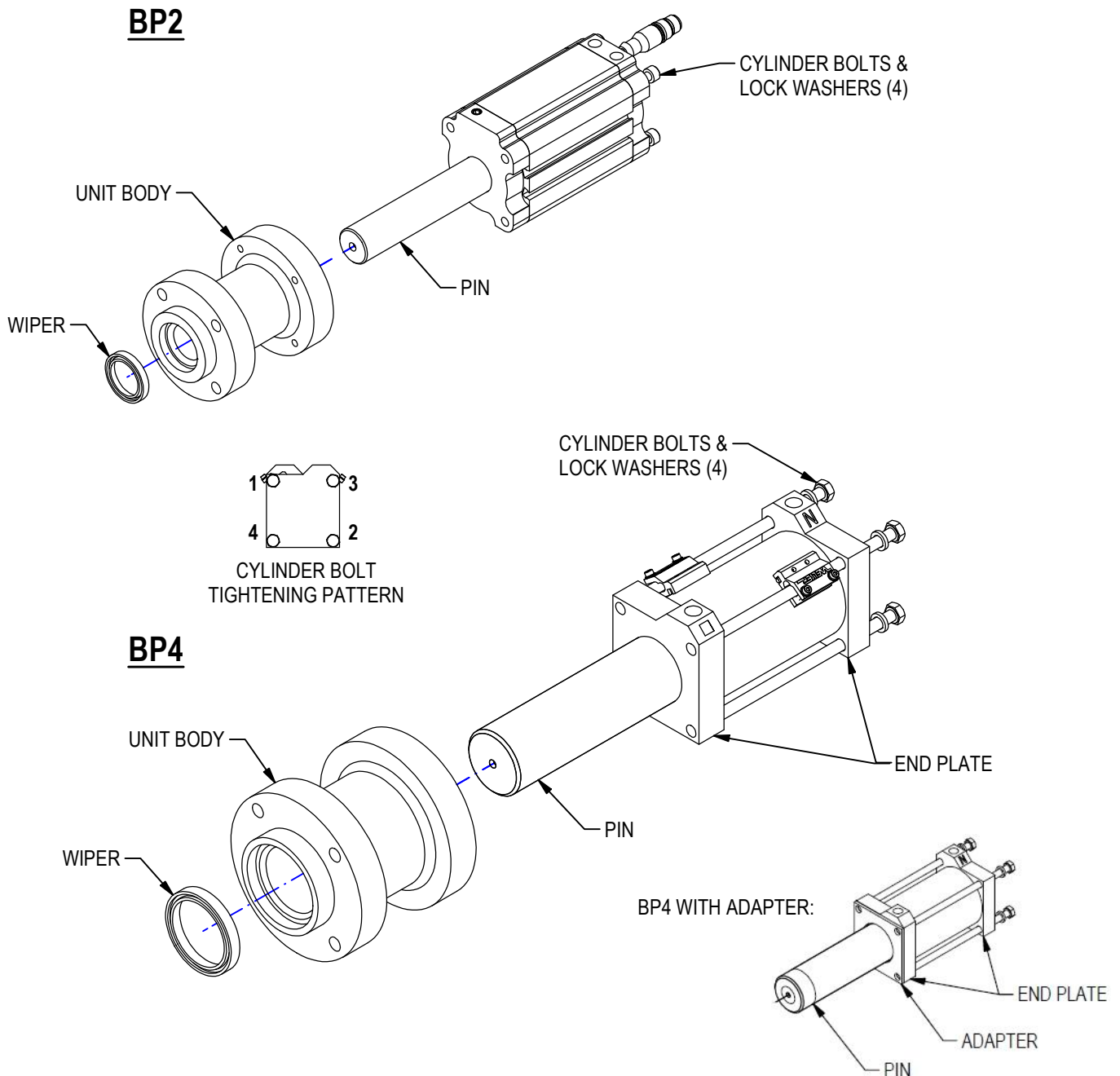

TO REPLACE WIPER & CYLINDER SEALS: BP1

Remove air lines from the cylinder. Remove lockout unit from mount.

For units with Spring Extend option:

1. Loosen and remove spring housing screws & lock washers.
2. Remove spring housing and spring to access pin, wiper and seals.

For units without Spring Extend option:

1. Loosen and remove screws & lock washers.
2. Remove end cap.

To replace wiper:

1. Push pin into unit body approx 1/2" to access wiper.
2. Remove wiper. Note orientation of groove.
3. Clean wiper cavity of debris.
4. Install new wiper with groove placement same as old wiper.
Use a flat surface/plate to install wiper; a hand press is recommended.

To replace cylinder seals:

1. Remove pin and piston.
2. Replace inner pin seal, piston seal, and end cap seal.

Reassemble unit, being sure seals are correctly seated, and spring is in place (if applicable).

1. Secure with screws & lock washers.
2. Tighten to 4.8 in-lb. [0.54Nm] to pattern shown.
3. Use removable thread adhesive on all fasteners.
4. Install cylinder switch if applicable. Install unit to mount.
5. Install air lines, making sure they are free of contaminants.

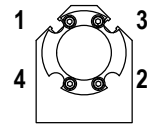
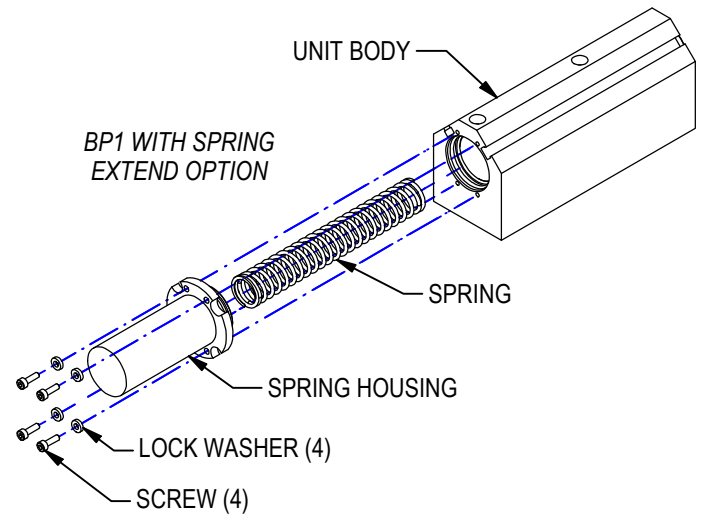

BOLT TIGHTENING PATTERN

ALL CYLINDER COMPONENTS (WIPERS, SEALS, ETC.) SHOULD BE COATED WITH MAGNALUBE G OR EQUIVALENT.

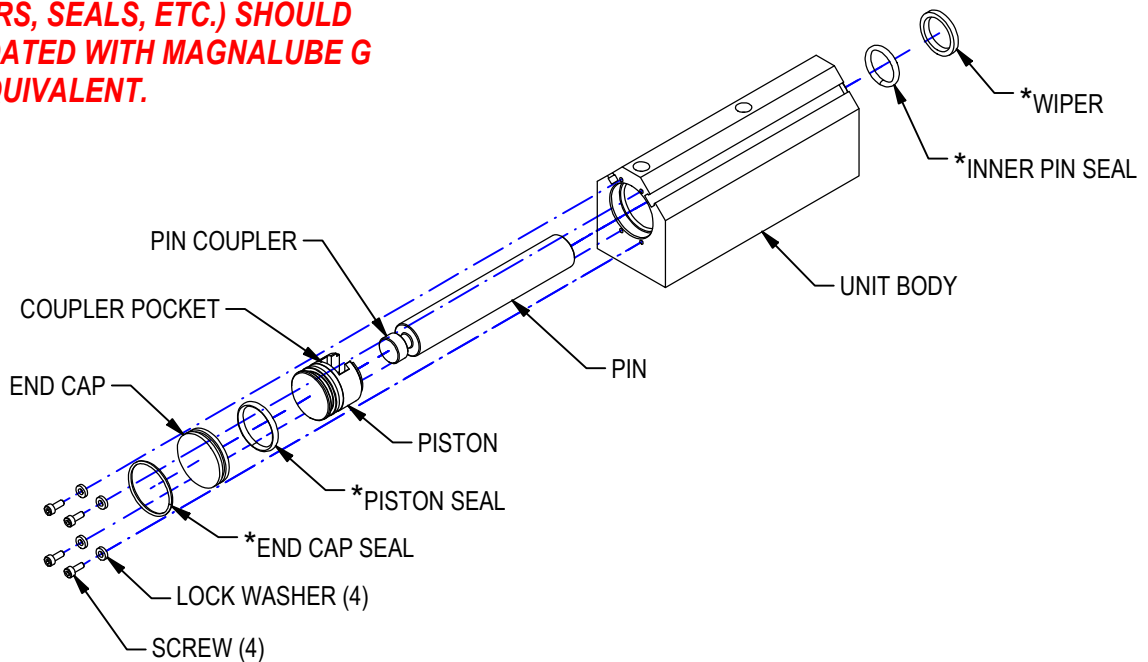

* INCLUDED IN SEAL KIT

BP2 CYLINDER MAINTENANCE

Cylinder seal kit includes: Cap seals, wiper, piston seals, port seals and snap rings.

1. Remove air lines from the cylinder. Remove lockout unit from mount. Remove cylinder switch if applicable.
2. Remove the cylinder screws & lock washers. **Note: unit end cap is under pressure, use caution removing screws.**
3. Remove rear cap & tube, noting port orientation. Replace cap seal.
4. Piston is held in place on pin with snap rings on either side. Remove end snap ring, slide piston off pin.
5. Replace piston inner and outer seals.
6. To access inner cap seal, slide pin out of unit. Remove wiper. Replace cap seals.
7. See wiper replacement instructions on sheet 4.
8. Replace internal port seals at both ends of cylinder tube.
9. Reassemble unit being sure seals are correctly seated, spring is in place, and ports are in proper position.
10. Secure with screws & lock washers. Tighten to 14 ft.lb. to pattern shown.
11. Use removable thread adhesive on all fasteners.
12. Install cylinder switch if applicable. Install unit to mount. Install air lines, making sure they are free of contaminants.

ALL CYLINDER COMPONENTS (WIPERS, SEALS, ETC.) SHOULD BE COATED WITH MAGNALUBE G OR EQUIVALENT.

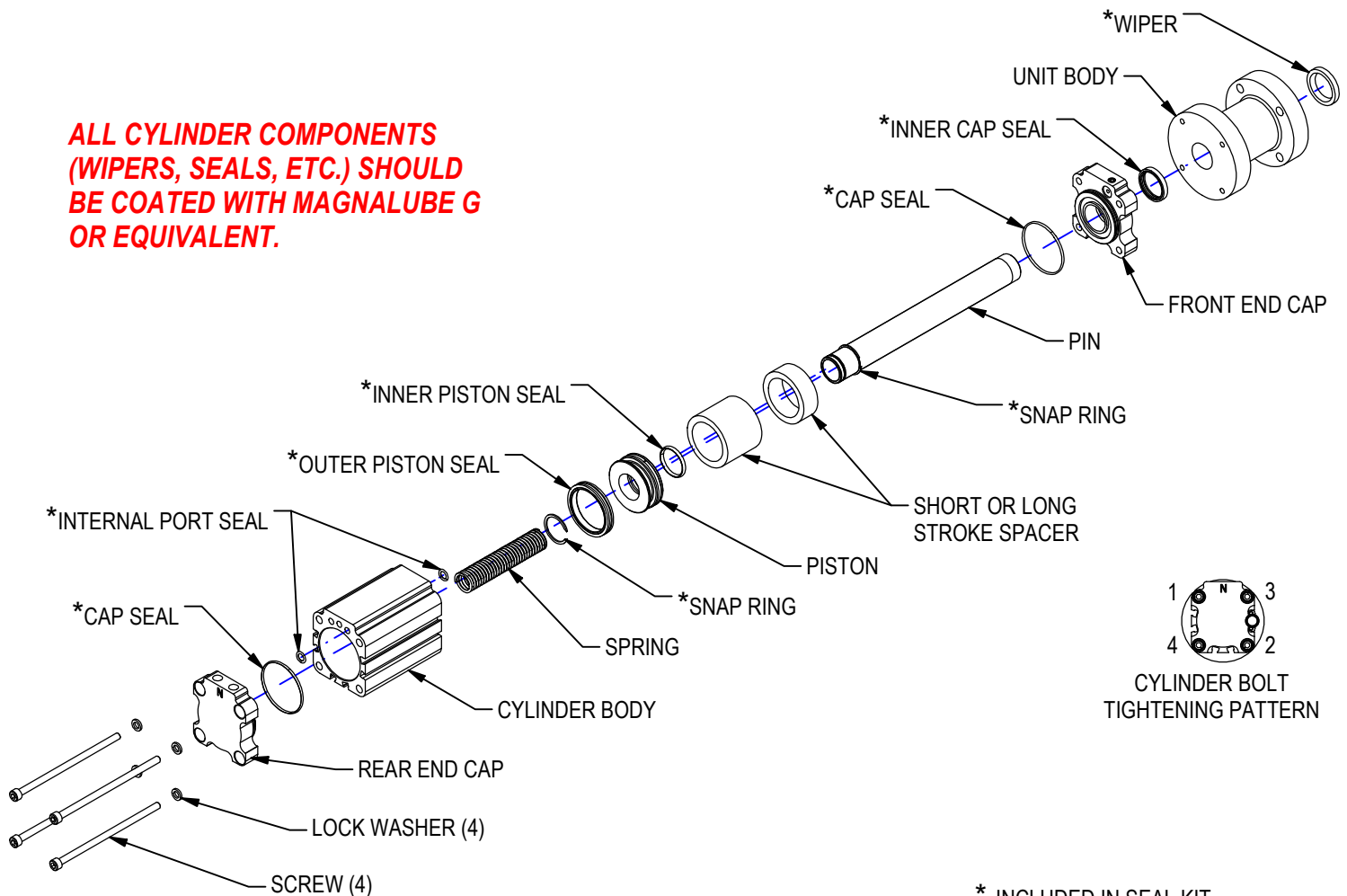

* INCLUDED IN SEAL KIT

BP4 CYLINDER MAINTENANCE

Cylinder seal kit includes: Bumper seals, rod wiper(s), piston seals, adapter seals. Additional seals/wipers are included with seal kits for double rod cylinders, and legacy designs. Not all seals may be used depending on the version being repaired.

NOTE: Gas spring spacer may be loose and fall out when disassembling cylinder.

1. Remove air lines from the cylinder. Remove lockout unit from mount. Remove cylinder switch if applicable.
2. Remove the cylinder tie rods & washers. **NOTE: Unit end cap is under pressure, use caution removing tie rods.**
3. Remove rear cap & tube, noting port orientation. Replace bumper seal.
4. Piston is held in place on pin with snap rings on either side. Remove end snap ring, slide piston off pin.
5. Replace piston inner and outer seals.
6. Remove cylinder front end cap. Replace bumper seal and inner seal.
7. Legacy units: to access adapter, slide pin out of unit. Remove wiper. Replace adapter seals.
8. See wiper replacement instructions on sheet 3.
9. Reassemble unit being sure tube seals are correctly seated, gas spring spacer is in place, and ports are in proper position.
10. Secure with tie rods & lock washers. Tighten to 15 ft.lb. to pattern shown.
11. Use removable Locktite on all fasteners.
12. Install cylinder switch if applicable. Install unit to mount. Install air lines, making sure they are free of contaminants.

ALL CYLINDER COMPONENTS (WIPERS, SEALS, ETC.) SHOULD BE COATED WITH MAGNALUBE G OR EQUIVALENT.

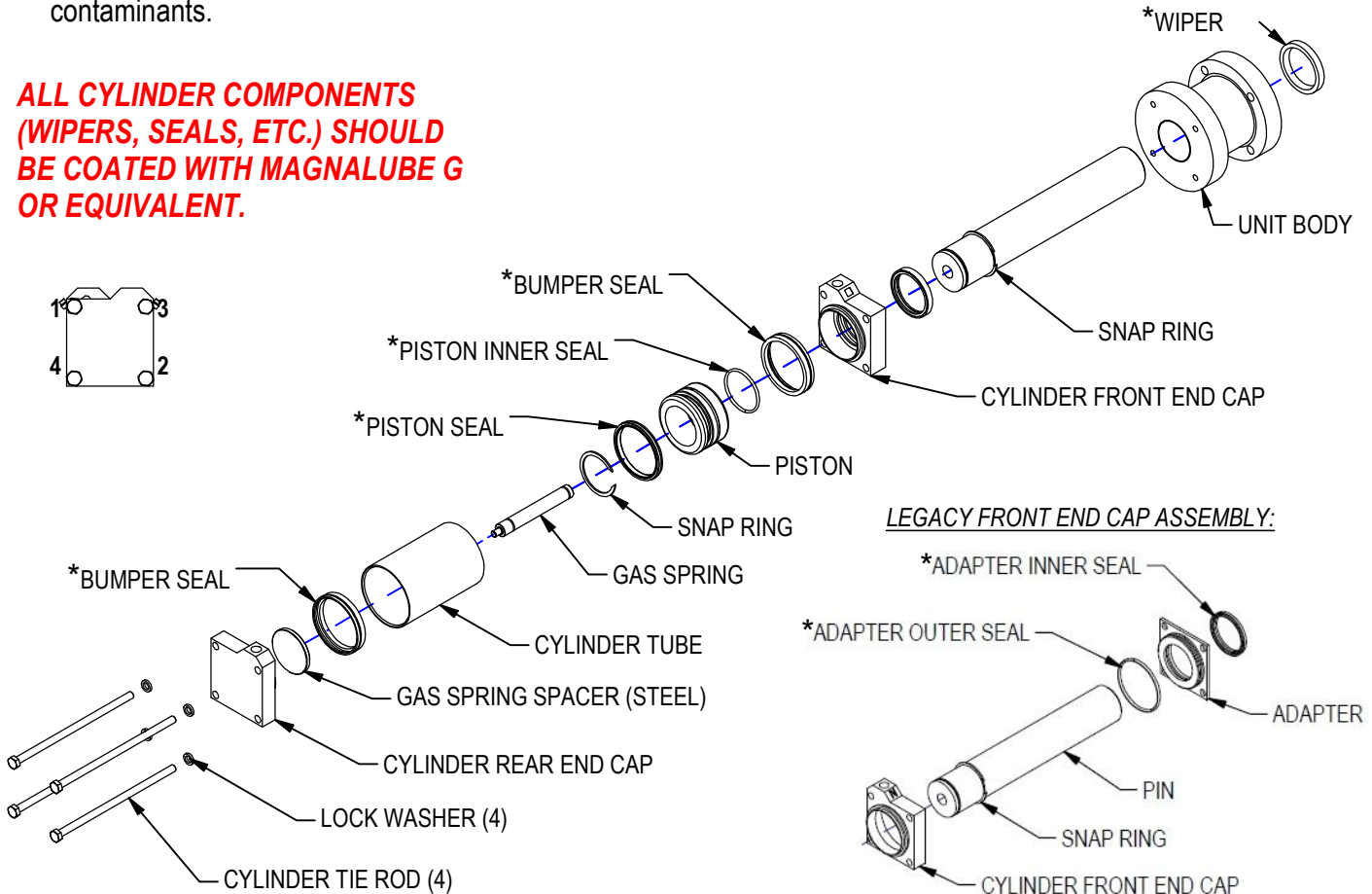

LEGACY FRONT END CAP ASSEMBLY:

BUILD DATE 4/23 AND EARLIER

* INCLUDED IN SEAL KIT

BP4 GAS SPRING MAINTENANCE

NOTE: Gas spring spacer may be loose and fall out when disassembling cylinder.

1. Remove air lines to cylinder.
2. Remove the cylinder tie rods & washers. **Note: unit end cap is under pressure, use caution removing tie rods.**
3. Remove rear cap & tube, noting port orientation.
4. Gas spring is located inside pin.
5. Replace gas spring.
6. Reassemble unit being sure gas spring spacer is in place (in end cap), tube seals are correctly seated and ports are in proper position.
7. Secure with tie rods & lock washers. Tighten to torque and pattern shown on sheet 4.
8. Use removable Locktite on all fasteners.

**ALL CYLINDER COMPONENTS
(WIPERS, SEALS, ETC.) SHOULD
BE COATED WITH MAGNALUBE G
OR EQUIVALENT.**

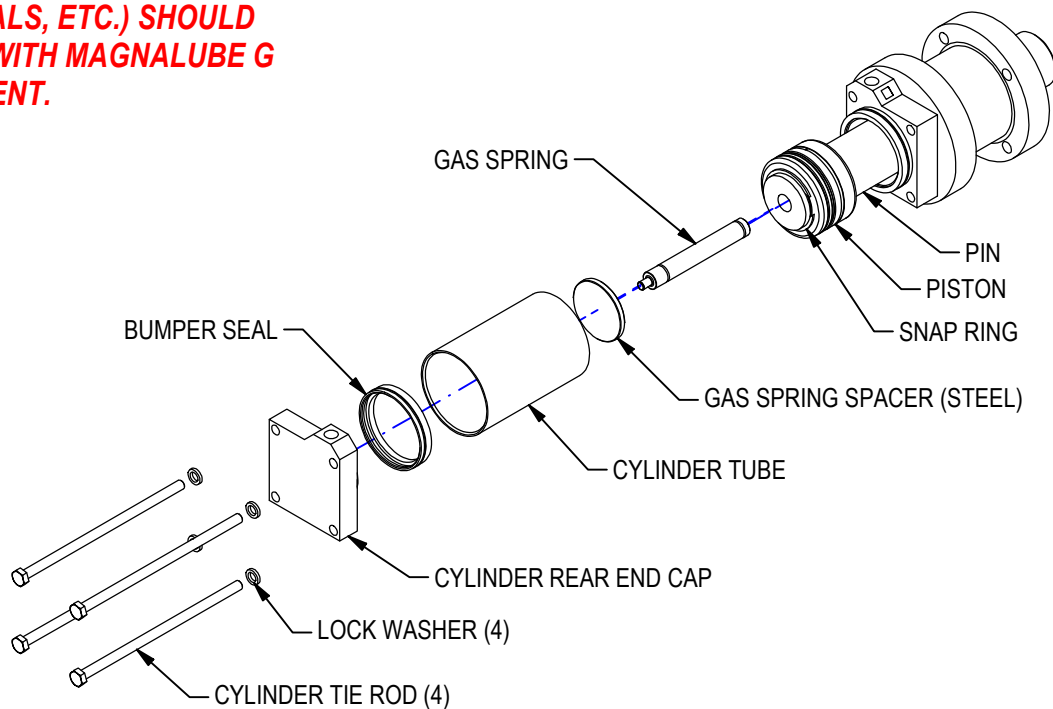

REPLACING TIE ROD CYLINDER SWITCH

1. BEFORE REMOVING OLD SWITCH: NOTE SENSOR PLACEMENT! FOR SWITCHES WITH TWO SENSORS, EACH WILL BE TAGGED WITH A BAND AROUND THE WIRE INDICATING S1 AND S2 (OR S01 AND S02).
2. TO REMOVE SWITCH, REMOVE BOLTS AND WASHERS FROM BRACKET. SLIDE BRACKET OUT FROM TIE ROD.
3. SENSOR IS SNAPPED INTO BRACKET. REMOVE.
4. INSTALL NEW SWITCH SENSOR FLUSH INTO BRACKET, BEING CAREFUL TO MATCH SENSOR CORRECTLY TO LOCATION ON CYLINDER.
5. LOCATE BRACKET TO CYLINDER, SLIDE ON TO TIE ROD. SECURE WITH BOLTS & WASHERS.

